



model **SP829SS**
AXION® MSR Showerhead

FEATURES & BENEFITS

SHOWER HEAD

AXION® MSR stainless steel showerhead uses a hydrodynamic design to give equal distribution of water throughout the entire footprint of flow.

COMFORT

The violent showerhead flows of the past have been replaced by breaking the streams of water into smaller individual droplets to provide a more comfortable shower environment.

OPTIONS

To see all options for this model, visit www.hawesco.com



SPECIFICATIONS

Model SP829SS AXION® MSR hydrodynamic designed stainless steel showerhead with 20 gpm (75.7 L) flow control and 1" IPS inlet.

APPLICATIONS

Specifically, this showerhead can be used with almost any Haws shower or combination model, with the use of a 1" IPS inlet.

- NOTES:**
1. IF NECESSARY, USE DOW CORNING 832 SEALANT PLACING 5 SMALL BEADS ON THE MALE THREADS OF MATING PART (JUST ABOVE THE FIRST THREAD).

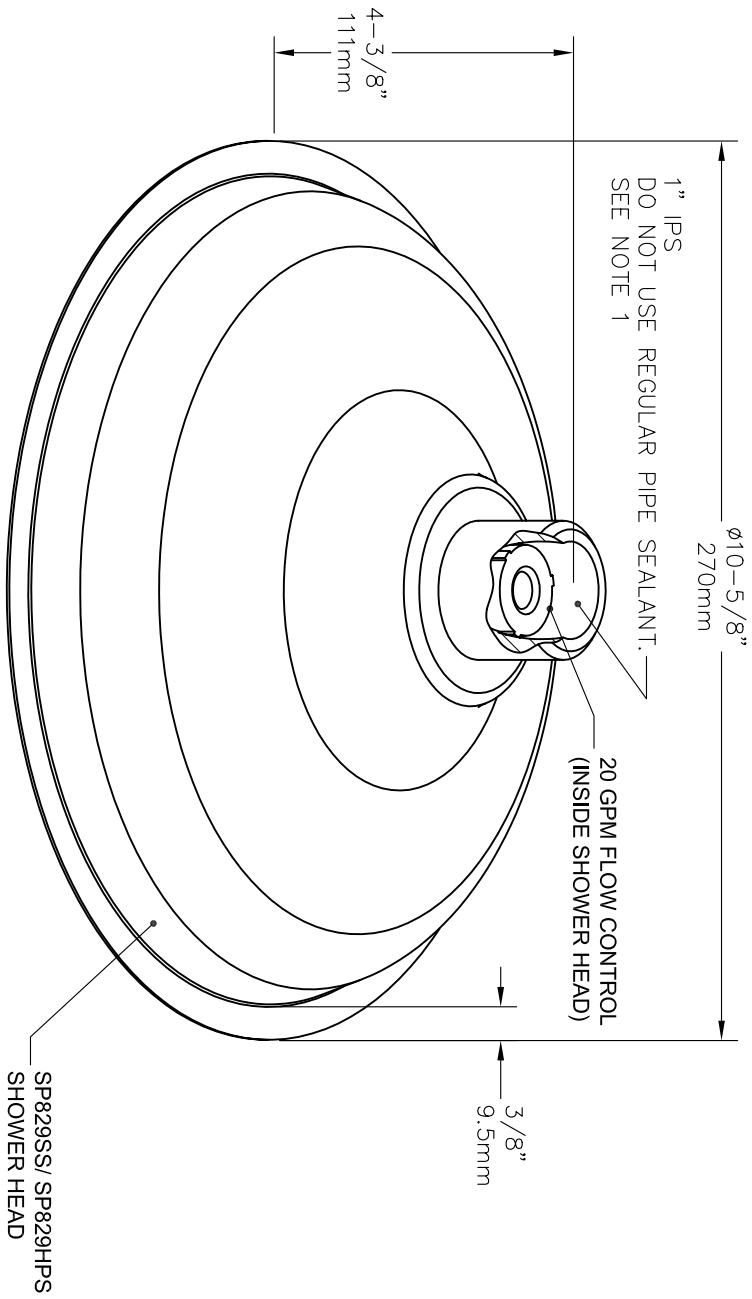

Haws Corporation		1455 KLEPPE LANE SPARKS, NEVADA 89431 (775) 359-4712 FAX (775) 359-7424 E-MAIL: HAWS@HAWSCCO.COM WEBSITE: WWW.HAWSCCO.COM	
FIGURE: 4358	DATE: 2/10/10	MODEL(S): SP829SS/ SP829HPS SHOWER HEAD	DATE: 02/20/10
ISSUED BY: HR	DATE: 2/10/10	INFO FAX DOC #:	DATE: 02/20/10
APPROVED BY: R	DATE: 2/10/10	ISSUING TYPE: INSTALLATION/EXHIBIT	DATE: 02/20/10
DRAWING NO. 15971A00		SHEET 1 OF 1	