

## FEATURES & BENEFITS

---

## OPTIONS

---

To see all options for this model, visit [www.hawSCO.com](http://www.hawSCO.com)



## SPECIFICATIONS

---

Model SP42 is a 6.25 gpm (23.7 L) flow control assembly.

## APPLICATIONS

---



# NOTES:

- 1 NOTE FLOW CONTROL ORIENTATION: NUBS ON FLOW CONTROL MUST BE FACING OPPOSITE OF FLOW SIDE.
- 2 SQUEEZE VALVE APPLICATION DOES NOT REQUIRE WASHER.
- 3 IF APPLICATION REQUIRES WASHER (SUPPLIED), IT MUST BE PLACED ON NUB SIDE OF FLOW CONTROL (OPPOSITE FLOW DIRECTION).

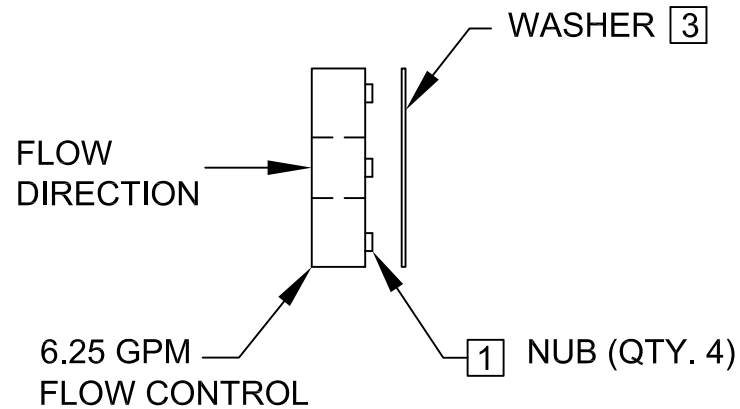
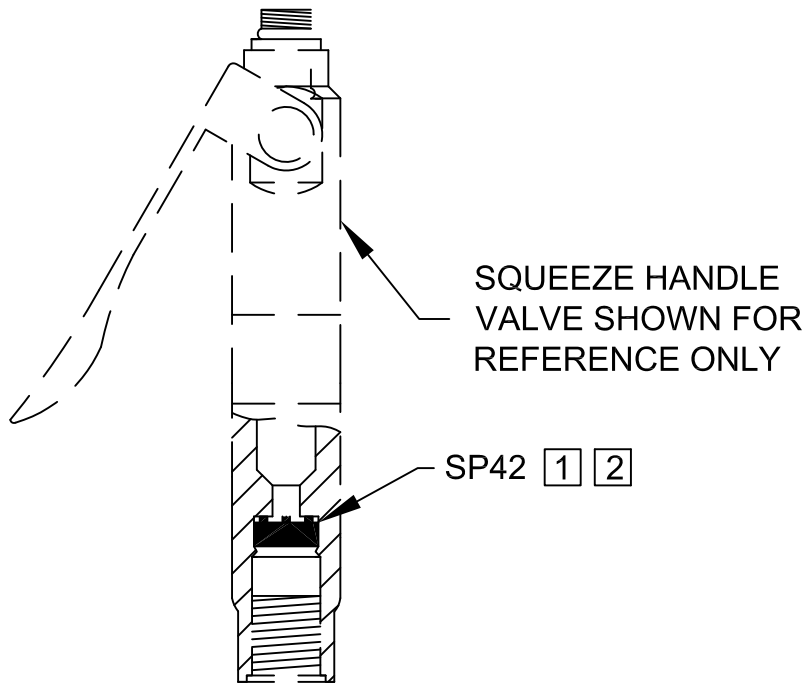
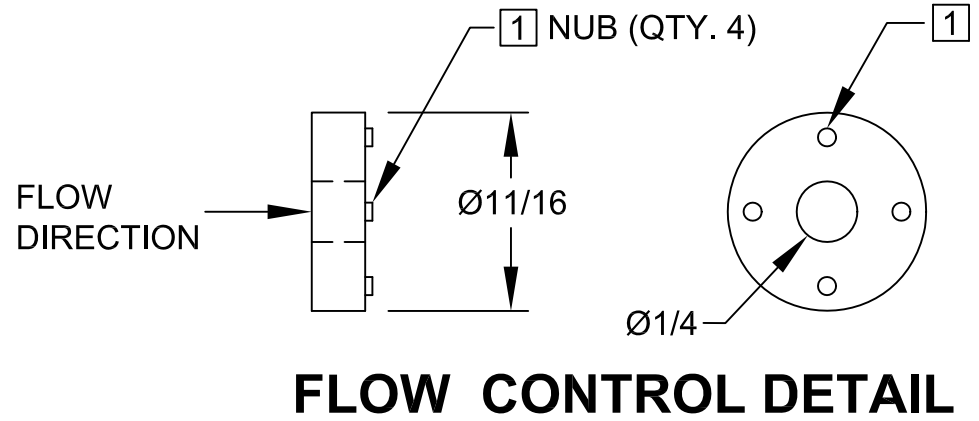

		1455 KLEPPE LANE SPARKS, NEVADA 89431 (775) 359-4712 FAX (775) 359-7424 E-MAIL: HAWS@HAWSCO.COM WEBSITE: WWW.HAWSCO.COM	
		PART NUMBER: 0002080316 DRAWING NUMBER: 14294A00 REV: 2	
ECN NO.:	REVISED PER:	BY:	MODEL(S):
J MAY	ECN: 4314	IR	SP42 6.25 GPM FLOW CONTROL
APPROVED:	DATE:	CHKD:	INFO FAX DOC #: 27742
	09/27/98		SCALE: NA DRAWING TYPE: INSTALLATION/FAXBACK
		SIZE: A SHEET 1 OF 1	