

Installation Instructions

HCR8 Refrigeration Packages

NOTICE: This water cooler must be connected to the water supply using a dielectric coupling.

IMPORTANT! INSTALLER PLEASE NOTE.

The grounding of electrical equipment such as telephone, computers, etc., to water lines is a common procedure. This grounding may be in the building, or may occur away from the building. This grounding can cause electrical feedback into a water chiller, creating an electrolysis which causes a metallic taste or an increase in the metal content of the water. This condition is avoidable by using the proper materials indicated below.

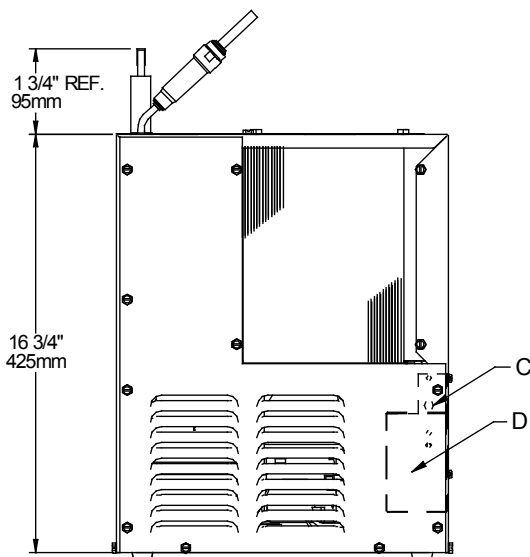
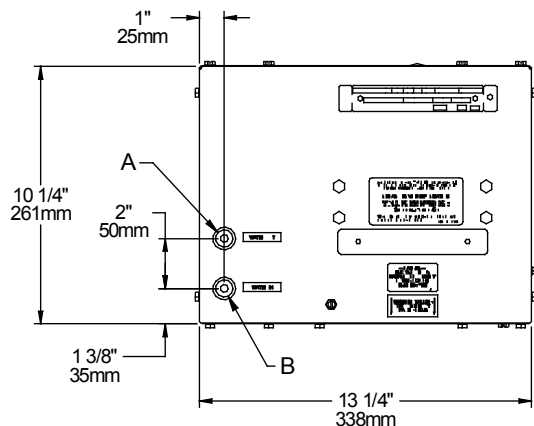

LEGEND

A = 1/4" O.D. TUBE WATER OUTLET C = TEMPERATURE ADJUSTMENT
B = 1/4" O.D. TUBE WATER INLET D = ELECTRICAL

INSTALLATION

1. When mounting unit in an open area, to insure proper ventilation, maintain a 4" (102mm) clearance from cabinet louvers on each side of cooler. When mounting unit in a cavity or behind a wall maintain minimum space of 4" (102mm) on each side, 4" (102mm) on the top and a depth of 12" (305mm).
2. Water inlet is 1/4" (6 mm) O.D. tube. Contractor to supply the connections as required.
3. Connecting lines to be of unplated copper, thoroughly flushed to remove all foreign matter before being connected to cooler. If flushing does not remove all particles, a water strainer should be installed in supply line. This cooler is manufactured in such a manner that it does not in any way cause taste, odor, color or sediment problems.
4. Connect cooler to building supply line with a shut-off valve and install the in-line strainer between the valve and cooler.
5. Electrical: Make sure power supply is identical in voltage, cycle, and phase to that specified on cooler serial plate. Never wire compressor directly to the power supply.
6. This chiller has been designed for use with potable water **ONLY**.

START-UP

1. Open supply line valve.
2. Purge air from all water lines by operating bubbler valve of fountain to which cooler is connected. Steady stream assures all air is removed.
3. Rotate fan to insure proper clearance and free fan action.
4. Connect to electrical power.

TROUBLE SHOOTING & MAINTENANCE

Temperature Control: Factory set at 50°F (± 5°) under normal conditions. For colder water, adjust screw on item no. 9 in clockwise direction.

Ventilation: Cabinet louvers and condenser fins should be periodically cleaned with brush, air hose or vacuum cleaner. Excess dirt or poor ventilation can cause no cold water and compressor cycling on the compressor overload protector.

Lubrication: Motors are lifetime lubricated.

Actuation of Quick Connect Water Fittings: Cooler is provided with lead-free connectors which utilize an o-ring seal. To remove tubing from the fittings, relieve water pressure, push in on gray collar while pulling on the tubing. To insert tubing, push tube straight into fitting until it reaches a positive stop, approximately 3/4".

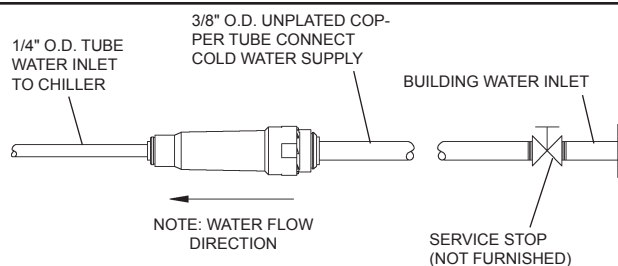

OPERATION OF QUICK CONNECT FITTINGS

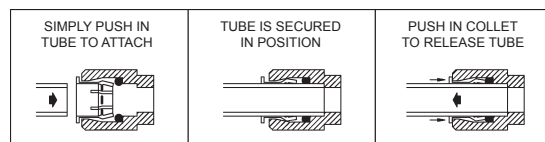

PUSHING TUBE IN BEFORE PULLING IT OUT HELPS TO RELEASE TUBE

115V ITEMIZED PARTS LIST

ITEM NO.	PART NO.	DESCRIPTION
1	0000000886	KIT - EVAP REPLACE ASSY
2	28478C	CABINET
3	98776C	KIT - CONDENSER/DRIER
4	98775C	KIT - FAN MTR/BLADE/NUT/SHROUD
5	20282C	BRACKET - FAN MOUNTING
6	98778C	KIT - HEAT EXCHANGER/DRIER
7	66703C	DRIER
*8	36322C	COMPRESSOR SERVICE PAK
9	98773C	KIT - COLD CONTROL/SCREWS
10	28477C	PANEL - FRONT
11	0000000238	KIT - ELECT/RELAY/COVER/OL
12	98777C	KIT - COMPRESSOR MTG HDWE
13	50930C	BUMPER
14	27303C	BASEPLATE
15	22300C	PANEL - REAR
16	55996C	IN-LINE STRAINER

***INCLUDES RELAY & OVERLOAD. IF UNDER WARRANTY, REPLACE WITH SAME COMPRESSOR USED IN ORIGINAL ASSEMBLY.**

NOTE: All correspondence pertaining to any of the above water cooler or orders for repair parts MUST include model number and serial number of cooler, name and part number of replacement part.

220V - 50/60HZ ITEMIZED PARTS LIST

ITEM NO.	PART NO.	DESCRIPTION
4	0000000244	KIT - FAN MTR/BLADE/NUT/SHROUD (50 HZ)
*8	1000002147	COMP. SERVICE PAK (50 HZ)
11	98751C	KIT - ELECT/RELAY/COVER/OL (50 HZ)
17	56237C	SHROUD

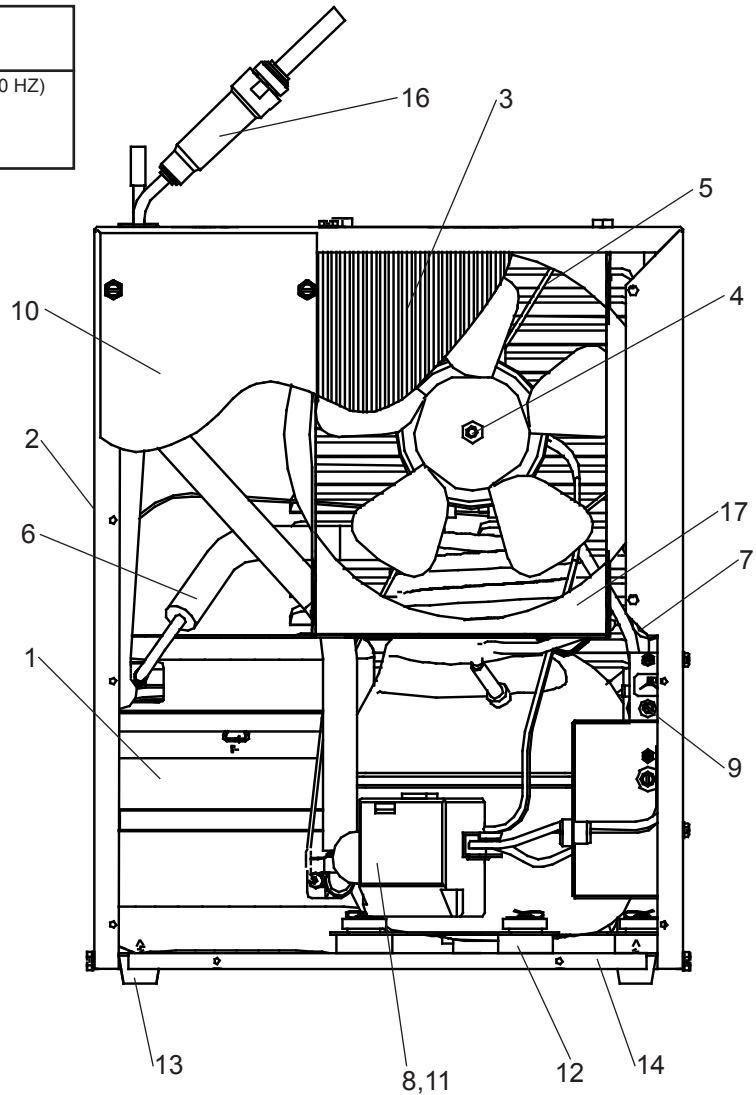
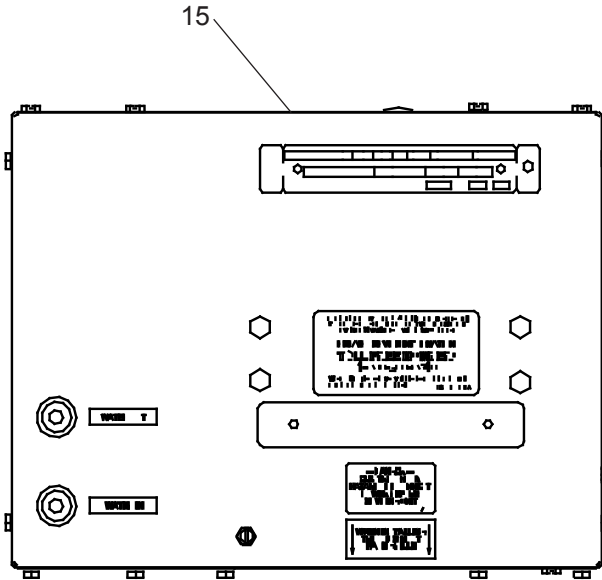

WIRING DIAGRAM

