

PARTS BREAKDOWN

ITEM	MODEL		DESCRIPTION
	H1001.8	H1001.8HPS	
1	BP6	BP6HPS	BACK PANEL
2	0006983506	0006983506	SPANNER WRENCH
3	6463	6463PCP	STRAINER ASSY
4	5705	5705	HEAD W/LAMINAR INSERT (STYLE A OR STYLE B)
5	PBA6	PBA6	PUSH BUTTON ASSY
6	5874SS	5874SS	VALVE
7	PBM1000	PBM1000	ACCESS PLATE
8	MTGFR.SM	MTGFR.SM	MOUNTING FRAME
9	HCR8	HCR8	CHILLER
10	0002626701	0002626719	GRILLE
11	0002082253	0002082253	DRIVER, NOZZLE .25 HEX

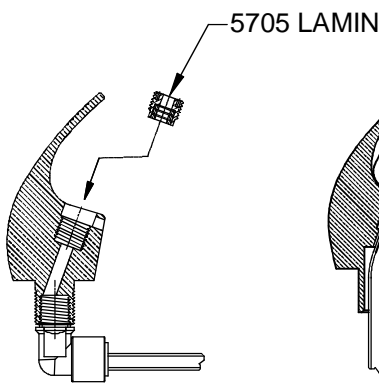

STYLE A
(TUBING CONNECTS TO ELBOW)

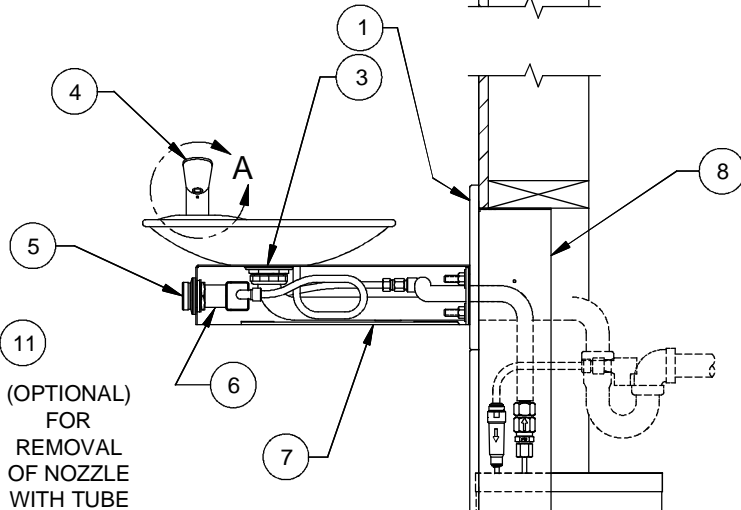
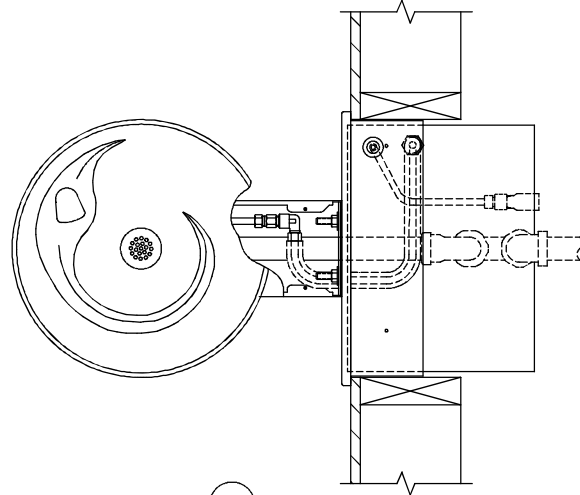
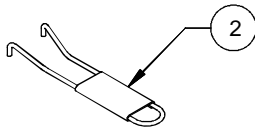
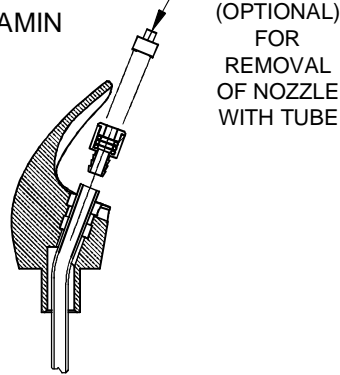

STYLE B
(TUBING CONNECTS TO INSERT ASSY)

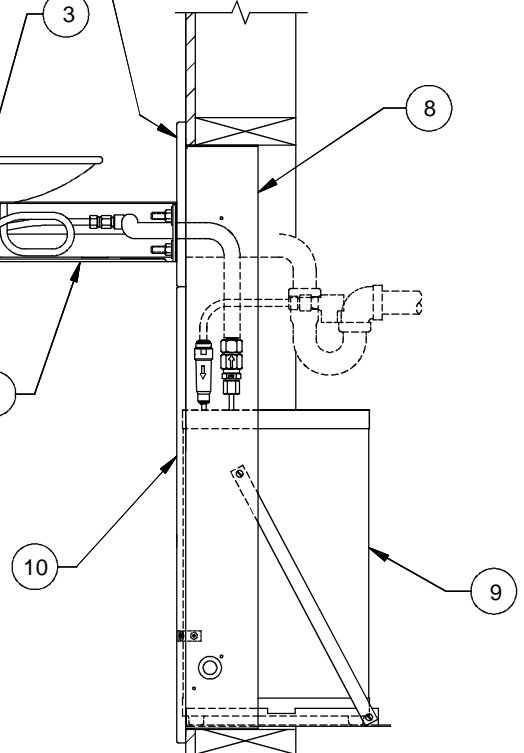

FOUNTAIN COULD HAVE EITHER STYLE



Haws[®]

1455 KLEPPE LANE
SPARKS, NEVADA 89431
(775) 359-4712 FAX (775) 359-7424
E-MAIL: HAWS@HAWSO.COM
WEBSITE: WWW.HAWSO.COM

ECN NO. ECN-4797	REVISED PER BY HM	MODEL(S)	PART NUMBER
DRAWN RTM	DATE 10/12/05	CHKD	0002080246
APPROVED	DATE	H1001.8/H1001.8HPS	DRAWING NO. 13365C00
		DRINKING FOUNTAIN	REV 17
		SCALE: 1:10	DRAWING TYPE: PARTS BREAKDOWN
		SIZE: A	SHEET 1 OF 1

WHEN ORDERING PARTS PLEASE SPECIFY MODEL NUMBER.