

NOTES:

1. HOLD ROUGH-IN DIMENSIONS $\pm 1/8"$ (3.2mm).
2. WHEN INSTALLING THIS UNIT, LOCAL, STATE, OR FEDERAL CODES SHOULD BE ADHERED TO. FOR DIMENSIONS (LOCATIONS), WASTE AND SUPPLY REQUIREMENTS OTHER THAN SHOWN, DIMENSIONS MARKED (*) MUST BE ADJUSTED ACCORDINGLY.
3. INSTALLER MUST PROVIDE TRAP FOR PROPER INSTALLATION.
4. REFER TO 5874SS OPERATION AND MAINTENANCE MANUAL FOR PUSH BUTTON AND VALVE INSTALLATION/MAINTENANCE INSTRUCTIONS.
5. REFER TO MTGFR.SM INSTALLATION DRAWING FOR ROUGH-IN DIMENSIONS.
6. INSERT 5/16"-18 PANEL INSERTS FROM OPPOSITE SIDE AT LOCATIONS SHOWN BY DARKENED HOLES.
7. FOUNTAIN REMOVAL: FIRST REMOVE SCREWS AND THEN SQUEEZE CLIPS ON NUT RETAINER TO POP OUT. INSTALL IS REVERSE OF REMOVAL.
8. ALIGN HOLES IN CHILLER SUPPORT TRAY WITH HOLES IN FRAME AND FASTEN WITH #10 SHEET METAL SCREWS.

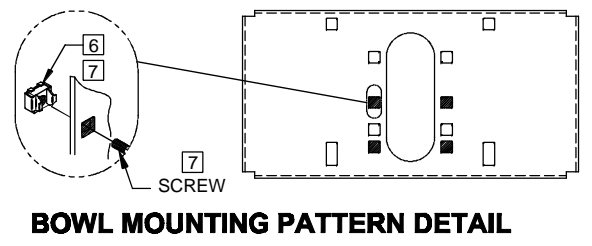
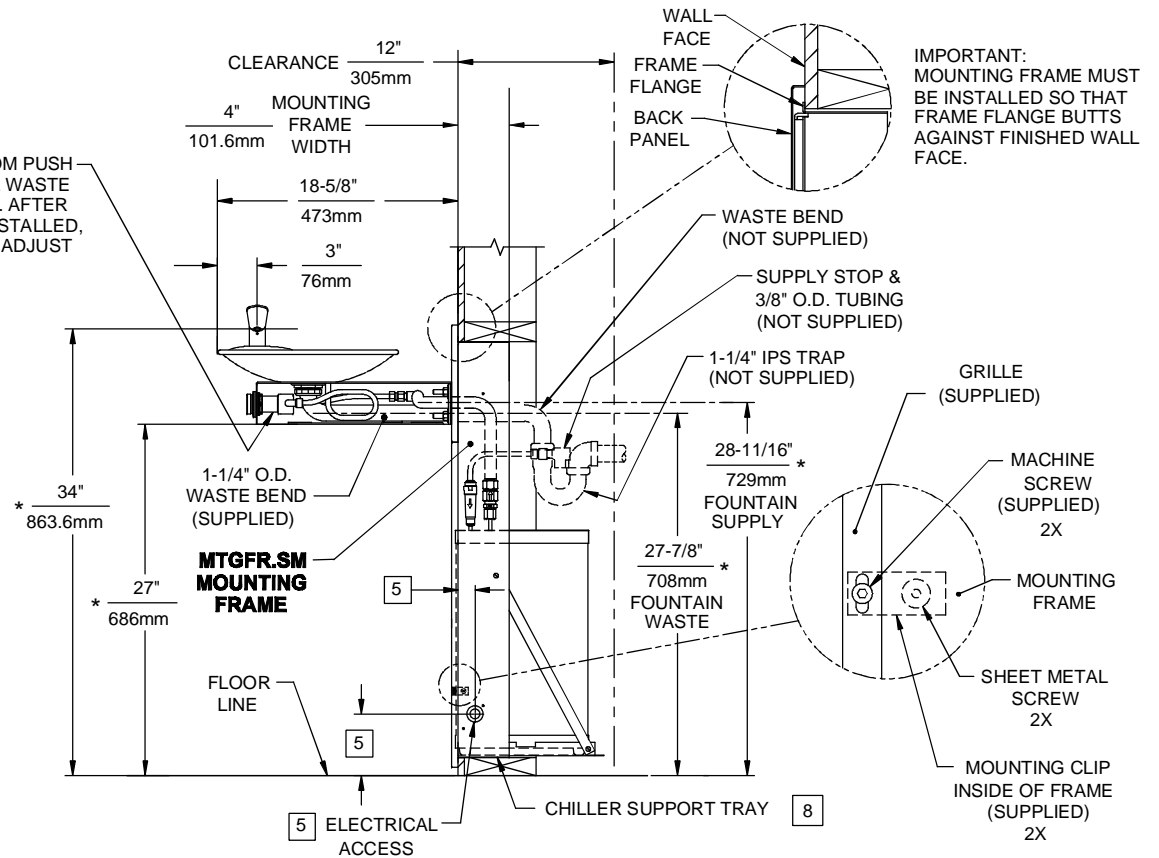
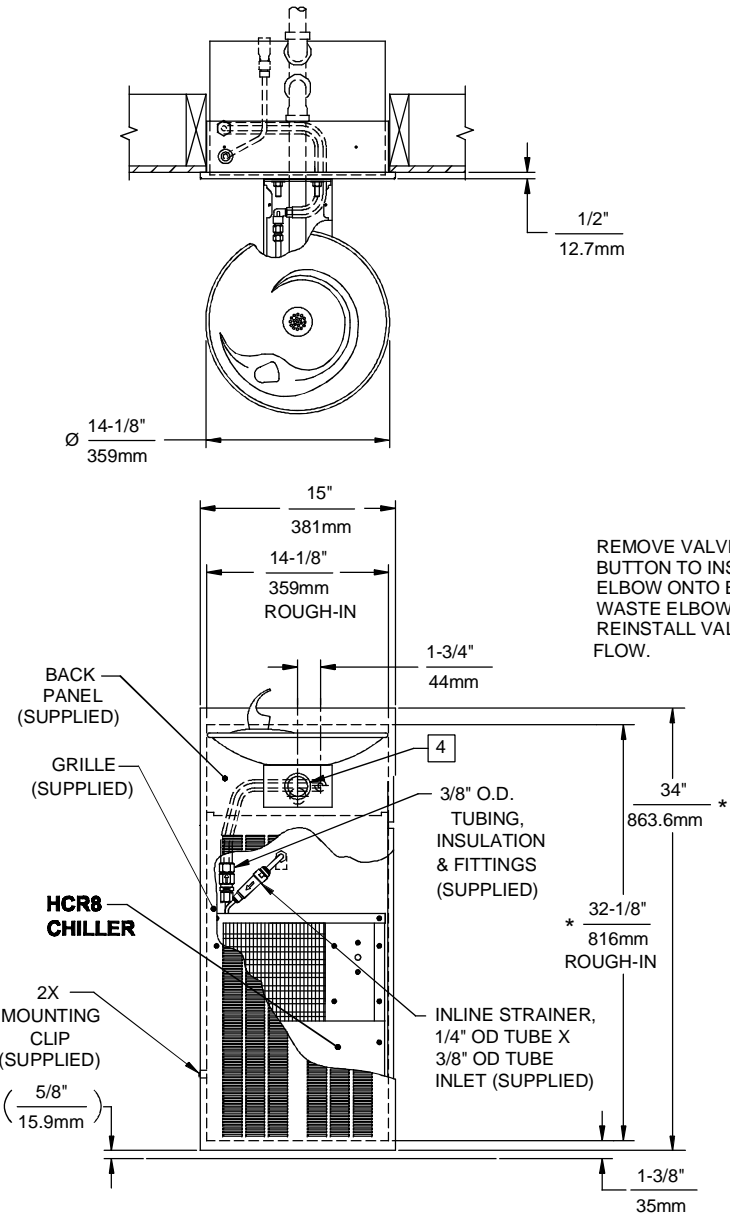

Haws[®]

1455 KLEPPE LANE
SPARKS, NEVADA 89431
(775) 359-4712 FAX (775) 359-7424
E-MAIL: HAWS@HAWSCO.COM
WEBSITE: WWW.HAWSCO.COM

ECN NO. REVISED PER BY:	MODEL(S)	PART NUMBER
ECN: 4797 HM	H1001.8/H1001.8HPS	0002080246.D
DRAWN: RTM	DATE: 07/97	CHK'D.:
APPROVED:	DATE:	SCALE: 1:15
		DRAWING TYPE: INSTALLATION
		SIZE: A
		SHEET 1 OF 1