



INSTALLATION, OPERATION & MAINTENANCE INSTRUCTIONS

1455 Kleppe Lane ♦ Sparks, NV 89431-6467 ♦ (775) 359-4712 ♦ Fax (775) 359-7424
E-mail: haws@hawsco.com ♦ website: www.hawsco.com

No. 2080240 (2)

Model 9201EW Tempered Water Blending System

NOTE TO INSTALLER: Please leave this information with the Maintenance Department.

LIMITED WARRANTY

HAWS® warrants that this specific product is guaranteed against defective material or poor workmanship for a period of **three years from date of shipment**. HAWS liability under this warranty shall be discharged by furnishing without charge F.O.B. HAWS Factory any goods, or part thereof, which shall appear to the Company upon inspection to be of defective material or not of first class workmanship, provided that claim is made in writing to Haws within a reasonable period after receipt of the product. Where claims for defects are made, the defective part or parts shall be delivered to the Company, prepaid, for inspection. HAWS will not be liable for the cost of repairs, alterations or replacements, or for any expense connected therewith made by the owner or his agents, except upon written authority from HAWS, Sparks, Nevada. HAWS will not be liable for any damages caused by defective materials or poor workmanship, except for replacements, as provided above. Buyer agrees that Haws has made no other warranties either expressed or implied in addition to those above stated, except that of title with respect to any of the products or equipment sold hereunder and that HAWS shall not be liable for general, special, or consequential damages claimed to arise under the contract of sale.

The thermostatic mixing valve manufactured by HAWS is warranted to function if installation and maintenance instructions provided are adhered to. The units also must be used for the purpose, which they were intended. This product is intended to supplement first-aid treatment. Due to widely varying conditions HAWS cannot guarantee that the use of this emergency equipment will prevent serious injury or the aggravation of existing or prior injuries.

NO OTHER WARRANTIES EXPRESSED OR IMPLIED ARE AUTHORIZED, PROVIDED OR GIVEN BY HAWS.

SHOULD YOU EXPERIENCE DIFFICULTY WITH THE INSTALLATION OF THIS MODEL, OR REPLACEMENT PARTS, PLEASE CALL:

TECHNICAL SUPPORT: 1-800-766-5612

FOR CUSTOMER SERVICE: 1-888-640-4297

INSTALLATION, OPERATION & MAINTENANCE INSTRUCTIONS

Valve operating principle:

The Haws Corporation 9201EW Emergency Valve thermostatically mixes hot and cold water to provide a safe fluid supply for emergency eyewash equipment. Additionally, to ensure a fail-safe water supply for emergency eyewash station, a cold water by-pass valve opens in the event of hot water pressure loss.

Valve features:

- Paraffin filled thermostat with industry leading response time.
- Tempered water: Temperature is factory set to 85°F (29°C).
- Tempered water: High temperature limit is factory set to 90°F (32°C).
- Cold water by-pass valve opens if hot water fails.
- Actively suspends hot water flow when cold water supply is lost to protect against scalding.

Valve sizing:

The flow capacity table shown below contains discharge flow rates @ 85°F (29°C) outlet temperature with the valve tested under the conditions described by ASSE 1071.

Flow Capacity								
Model No.	Min flow	Pressure drop across valve						Cold water
		5 PSI	10 PSI	20 PSI	30 PSI	40 PSI	45 PSI	By-pass @ 30 PSI
9201EW	1.0* GPM	4.1 GPM	5.8 GPM	8.2 GPM	10 GPM	11.5 GPM	12.2 GPM	3.8 GPM

* Denotes minimum flow rate without re-circulation.

Valve specifications:

- Maximum operating pressure: 125 PSI
- Minimum / Maximum hot water temperature: 120°F / 180°F (49°C - 82°C).
- Tempered water temperature adjustment range: 60°F – 90°F (15°C - 32°C)
- Compliance/Listings: ASSE 1071 and applicable sections of CSA B125.3.

IMPORTANT

To ensure the proper operation of the 9201EW valve it is essential to:

- Properly size the valve for each application.
- Keep the outlet temperature set between 60°F and 90°F (15°C - 32°C).
- Haws recommends a weekly testing and recording of the outlet water temperature.
- Maximum cold water inlet temperature: 65° F per ASSE 1071.

Failure to comply with installation and/or maintenance instructions could result in valve failure.

INSTALLATION, OPERATION & MAINTENANCE INSTRUCTIONS

Valve operation:

Hot and cold water flows into the valve through two ports, marked "C" for cold and "H" for hot. The inlet water passes through check valves and valve seats into a mixing chamber, where the thermostat is located. The temperature setting is controlled via the tempered water temperature adjustment screw which is located at the front of the valve. (See Installation Drawing). If the inlet temperature fluctuates or the pressure changes, the thermostat moves an internal plunger which corrects outlet temperature back to the initial setting. In the event of cold water failure, the thermostat closes the hot seat. Additionally, the cold water by-pass valve provides adequate cold water flow if the hot inlet fails.

Valve installation instructions:

Installation and field adjustment of this device are the responsibility of the installer and shall be carried out in accordance with the following instructions:

1. This valve must be accessible for testing, adjustment and/or maintenance in its installed position.
2. If shutoff valves are installed for maintenance purposes, provisions shall be made to prevent unauthorized shutoff.
3. Flush the hot and cold supply lines prior to installation.
4. Connect the hot and cold supplies to the marked inlets.
5. Connect the outlet to the tempered water supply line.
6. Pressurize the emergency tempering valve and check all connections for leaks.

Installation test procedure:

1. Confirm the discharge temperature at the eyewash station. Reset the outlet temperature, if necessary, based on medical/safety authorities guidelines. (This establishes the pre-set level).
Note: Turning the temperature adjusting screw counterclockwise will increase the temperature.
2. Close the hot water supply: The cold water by-pass must open and provide significant flow.
3. Open the hot water supply: The outlet temperature should return to the pre-set level.
4. Close the cold water supply: The flow rate must comply with the maximum cold shut off flow allowed by ASSE 1071 for this valve size.
5. Open the cold water supply: The outlet temperature should return to the pre-set level.

Recommended valve testing procedure:

1. Open the eyewash station: Confirm and record the outlet temperature.
2. Close the hot water inlet: The cold water by-pass valve must open.
3. Open the hot water inlet: The outlet temperature should return to the pre-set level.
4. Close the cold water supply: The flow rate must comply with the maximum cold shut off flow allowed by ASSE 1071 for this valve size.
5. Open the cold water supply: The outlet temperature should return to the pre-set level.

INSTALLATION, OPERATION & MAINTENANCE INSTRUCTIONS

TROUBLESHOOTING PROCEDURE		
PROBLEM CONDITION		REPAIR CHECKLIST
1. Cold flow only.	a. b.	Confirm the hot water inlet pressure; it must be within +/- 10% of the cold inlet pressure. Confirm the hot water upstream valve is fully open.
2. Flow rate is too low.	a. b. c.	Confirm all upstream inlet valves are fully open. Confirm the downstream valve is fully open. Confirm the hot and cold inlet pressures; both supplies must be 30 PSI, minimum.
3. No flow.	a. b. c.	Confirm all upstream inlet valves are fully open. Confirm the downstream valve is fully open. Confirm the hot and cold inlet pressures; both supplies must be 30 PSI, minimum.
4. Significantly lower outlet temperature.	a. b.	Confirm the hot water inlet pressure; it must be within +/- 10% of the cold inlet pressure. Confirm the cold water bypass valve is free of debris. Clean if necessary.

INSTALLATION, OPERATION & MAINTENANCE INSTRUCTIONS

WEEKLY TEST RESULTS (ONE YEAR)*							
WEEK NO. (1 THRU 26)	OUTLET TEMP (° F)	COLD BY-PASS OPEN? (Y/N)	COLD WATER FAILURE? (PASS/FAIL)	WEEK NO. (27 THRU 52)	OUTLET TEMP (° F)	COLD BY-PASS OPEN? (Y/N)	COLD WATER FAILURE? (PASS/FAIL)
1				27			
2				28			
3				29			
4				30			
5				31			
6				32			
7				33			
8				34			
9				35			
10				36			
11				37			
12				38			
13				39			
14				40			
15				41			
16				42			
17				43			
18				44			
19				45			
20				46			
21				47			
22				48			
23				49			
24				50			
25				51			
26				52			

**Notice to testing personnel: This sheet should be used as a template for capturing the test results of this valve for one year. Please make a copy of this sheet for future testing prior to writing on this one.*

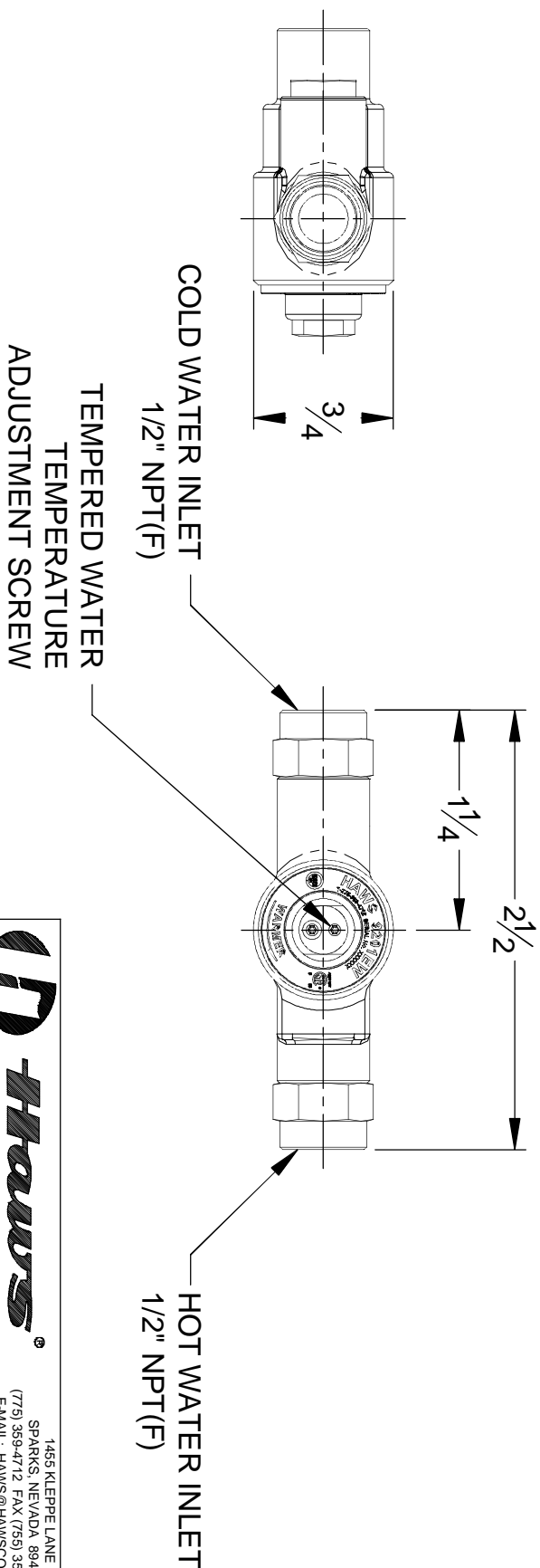
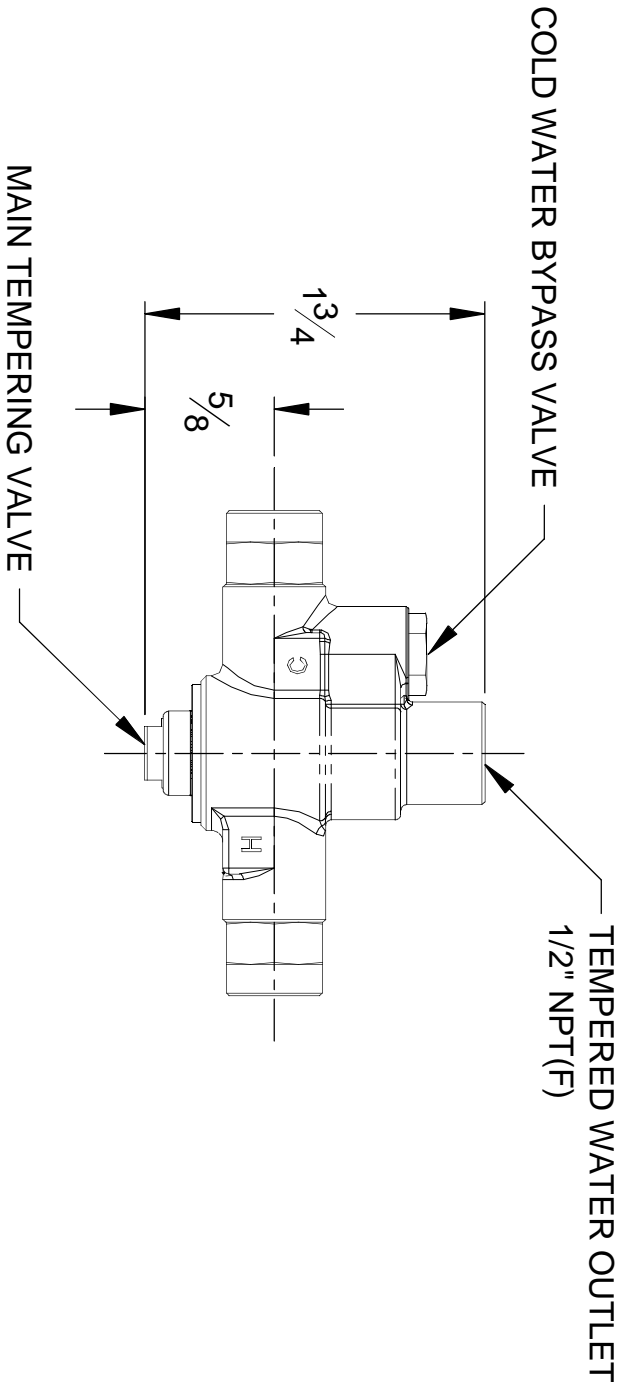

Haws

1455 KLEPPLE LANE
SPARKS, NEVADA, 89431
(775) 359-4712 FAX (755) 359-7424
E-MAIL: HAWS@HAWS.CO.COM
WEBSITE: WWW.HAWS.CO.COM

ECONO. REVISED PER BY:	MODEL(S)	PART NUMBER
4782 ECON. 4887 HAW	9201EW	0002080240.D
DATE: 10/02/12		DRAWING NO. 16218A
CHK'D:		REV 2
APPROVED:	SCALE: 1:1	DRAWING TYPE: INSTALLATION
DATE:	SIZE: A	SHEET 1 OF 1