



INSTALLATION, OPERATION & MAINTENANCE INSTRUCTIONS

1455 Kleppe Lane ♦ Sparks, NV 89431-6467 ♦ (775) 359-4712 ♦ Fax (775) 359-7424
E-mail: haws@hawsco.com ♦ website: www.hawsco.com

No. 2080191(8)

Model 8901B Hose Spray

NOTE TO INSTALLER: Please leave this information with the Maintenance Department.

LIMITED WARRANTY

HAWS® warrants that all of its products are guaranteed against defective material or poor workmanship for a period of **one year from date of shipment**. HAWS liability under this warranty shall be discharged by furnishing without charge F.O.B. HAWS Factory any goods, or part thereof, which shall appear to the Company upon inspection to be of defective material or not of first class workmanship, provided that claim is made in writing to company within a reasonable period after receipt of the product. Where claims for defects are made, the defective part or parts shall be delivered to the Company, prepaid, for inspection. HAWS will not be liable for the cost of repairs, alterations or replacements, or for any expense connected therewith made by the owner or his agents, except upon written authority from HAWS, Sparks, Nevada. HAWS will not be liable for any damages caused by defective materials or poor workmanship, except for replacements, as provided above. Buyer agrees that Haws has made no other warranties either expressed or implied in addition to those above stated, except that of title with respect to any of the products or equipment sold hereunder and that HAWS shall not be liable for general, special, or consequential damages claimed to arise under the contract of sale.

The emergency equipment manufactured by HAWS is warranted to function if installation and maintenance instructions provided are adhered to. The units also must be used for the purpose, which they were intended. This product is intended to supplement first-aid treatment. Due to widely varying conditions HAWS cannot guarantee that the use of this emergency equipment will prevent serious injury or the aggravation of existing or prior injuries.

NO OTHER WARRANTIES EXPRESSED OR IMPLIED ARE AUTHORIZED, PROVIDED OR GIVEN BY HAWS.

SHOULD YOU EXPERIENCE DIFFICULTY WITH THE INSTALLATION OF THIS MODEL, PLEASE CALL:

1-800-766-5612

FOR PARTS CALL:

1-800-758-9378

**(U.S.A. AND CANADA ONLY) MONDAY-THURSDAY: 6:00 A.M. – 4:00 P.M. PST
FRIDAY: 6:00 A.M – 1:00 P.M. PST**

LOCATION OF UNIT: The Model 8901B Hose Spray should be installed in close proximity to potential accident areas. It should be clearly identified free from obstructions and easy to access. In order to comply with state codes, the use of a vacuum breaker is required with all hand held eye/face wash and body spray units (Haws offers Model SP212).

Supply Line: The minimum recommended line size is 1/2" IPS with 30-90 psi (2-6 ATM) pressure. Where sediment or mineral content is a problem, an inlet filter is recommended.

Plumbing Connections: Inlet supply is male 1/2" IPS.

TROUBLESHOOTING	
PROBLEM	REPAIR CHECKLIST
1. No flow.	1. a. Check the main shut-off valve.
2. Insufficient water flow.	2. a. Verify minimum 30 psi (2 ATM) flowing supply line pressure. b. Probable clogging of flow control due to inadequate line flushing. Disassemble eyewash at inlet connection to gain access and clean rubber flow control.
	c. Unscrew eye/face wash head cap off to gain access to the buffer and clean it.
3. Valve leaks in shut-off position.	3. Refer to installation drawing. Clean valve washer and seat thoroughly, then reassemble the valve. If valve still leaks, contact HAWS and purchase VRKSP248 to repair valve.

For more information about Haws products, see our website: www.hawesco.com

ITEM	DESCRIPTION
1	EYE/FACE WASH HEAD 0002974804
2	SP42 FLOW CONTROL
3	SP248 VALVE ASSEMBLY
4	SP140 HOSE ASSEMBLY
5	SP176 HOSE SPRAY SIGN
6	SP170 TEST TAG
7	-
-	VRKSP248 VALVE REPAIR KIT

PARTS BREAKDOWN

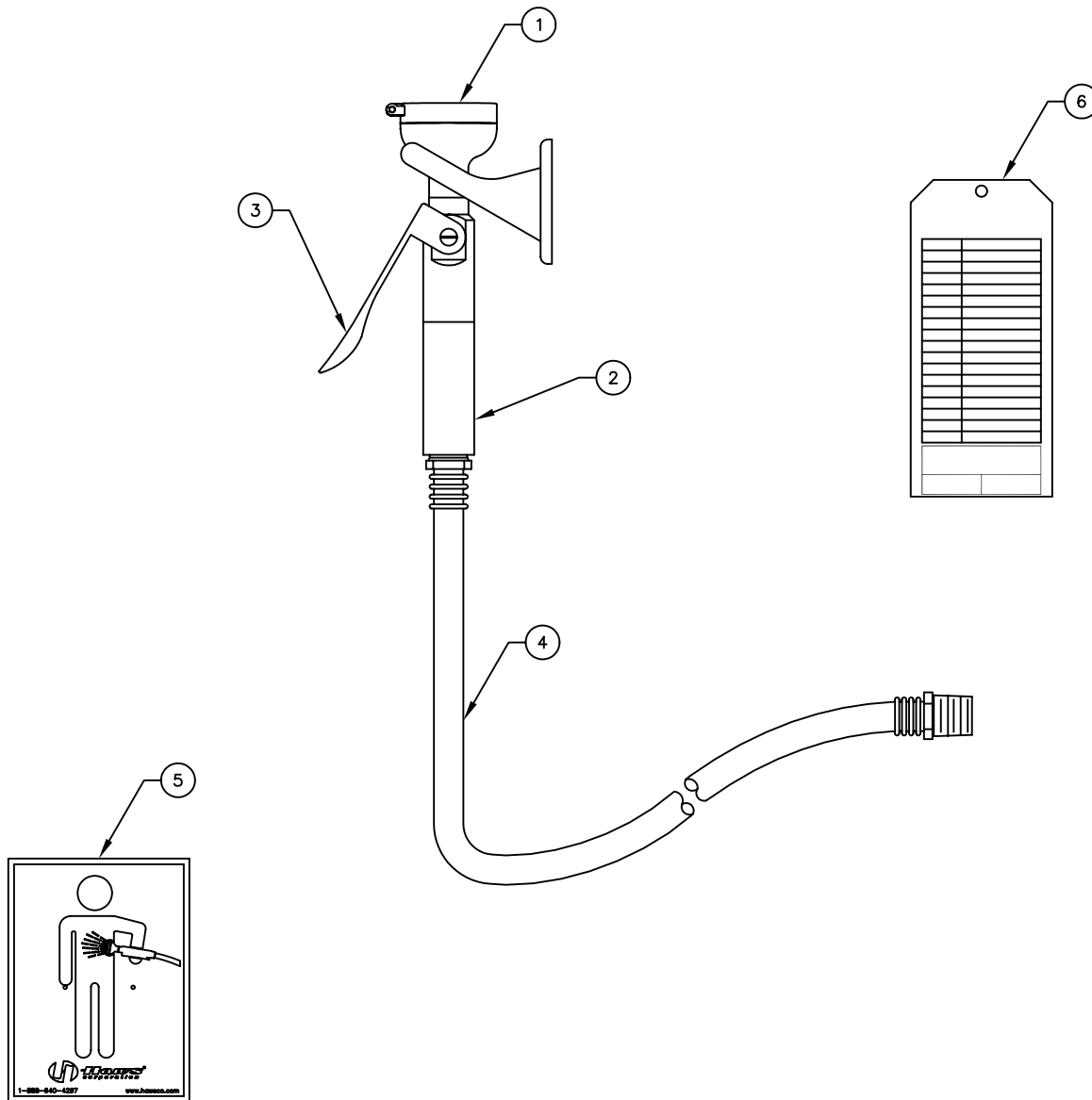

REV	DESCRIPTION	ECN	DATE	BY/APVD
8	UPDATED PER.	4367	12/3/09	IR
REVISIONS				

WHEN ORDERING PARTS PLEASE SPECIFY YOUR MODEL NUMBER

		1455 KLEPPE LANE SPARKS, NEVADA 89431 (775) 359-4712 FAX (775) 359-7424 E-MAIL: HAWS@HAWSO.COM WEBSITE: WWW.HAWSO.COM			
		DRAWN BY: CLF	DATE: 03/17/93	CHECK BY:	APPVD BY:
TITLE: 8901B EYE/FACE WASH BODY SPRAY			PART NUMBER: 0002080191		
DRAWING TYPE: PARTS BREAKDOWN			DRAWING NUMBER: 11510C00	REV. 8	

NOTES:

1. IN ORDER TO COMPLY WITH STATE CODES, THE USE OF A VACUUM BREAKER IS REQUIRED WITH ALL HAND HELD EYE/FACE WASH AND BODY SPRAY UNITS (HAW'S OFFERS MODEL SP212).

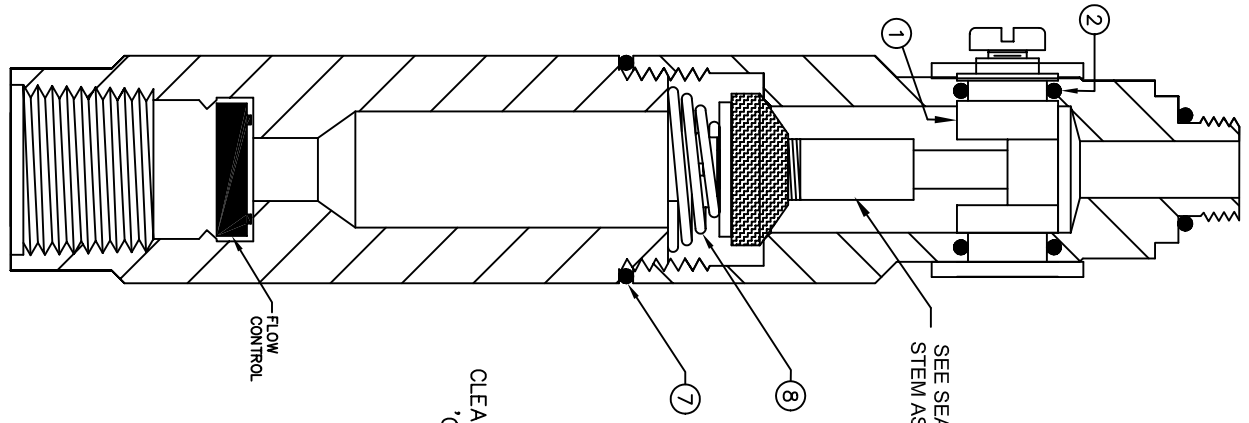

SEE SEAT & OPERATOR STEM ASSEMBLY DETAIL

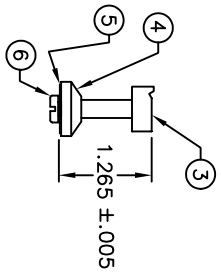

SEAT & OPERATOR STEM ASSEMBLY DETAIL

CLEAN VALVE SEAT AND WASHER THOROUGHLY, LUBRICATE 'O' RING WITH 'O' RING LUBE BEFORE REASSEMBLING.

ITEM NO.	QUANTITY	DESCRIPTION
①	1	CAM OPERATOR
②	2	'O' RING FOR CAM
③	1	OPERATOR STEM
④	1	SEAT WASHER
⑤	1	HOLDER WASHER
⑥	1	SCREW
⑦	1	'O' RING
⑧	1	SPRING

VALVE REPAIR DETAIL
MODEL VRK SP248
OPTIONAL

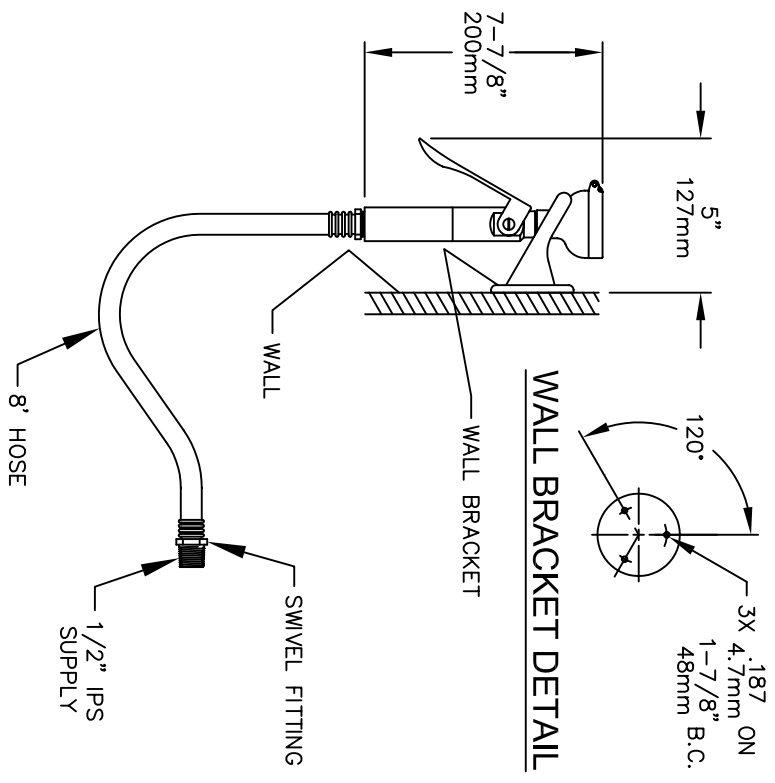

1455 KLEPPE LANE
 SPARKS, NEVADA 89431
 (775) 359-4712 FAX (775) 359-7424
 E-MAIL: HAW'S@HAWSCCO.COM
 WEBSITE: WWW.HAWSCCO.COM

EQN NO. 1	REVISED FOR	MODEL(S):	DATE: 05/20/91
CH	DATE: 05/20/91	INFO FAX DOC #:	289012
APPROVER:	DATE:	INSTALLATION/FABRICATION:	
SIZE: A	SHEET: 1	OF: 1	