

DETAIL A
VIEW ROTATED 180°

NOTE: PULL ROD AND HANDLE NOT ASSEMBLED. ORIENTATION OF HANDLE MUST BE IN UP POSITION WHEN FULLY CLOSED AND PULL ROD INSERTED IN HOLE SHOWN.

SP158B FREEZE PROTECTION VALVE
(SEE NOTES ON SHEET 2 & 3 FOR INSTALLATION INSTRUCTIONS.)

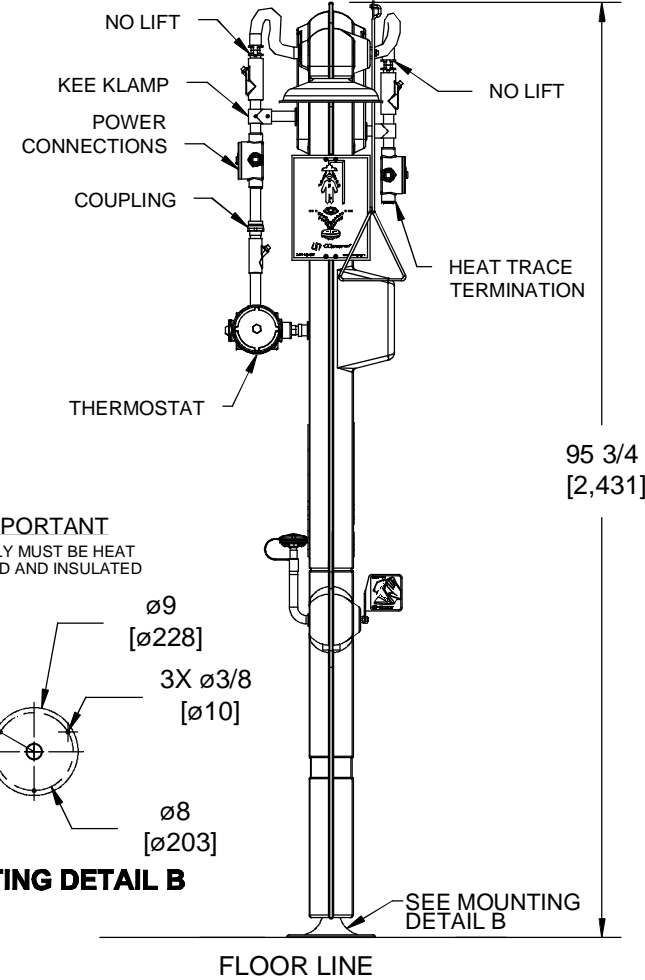
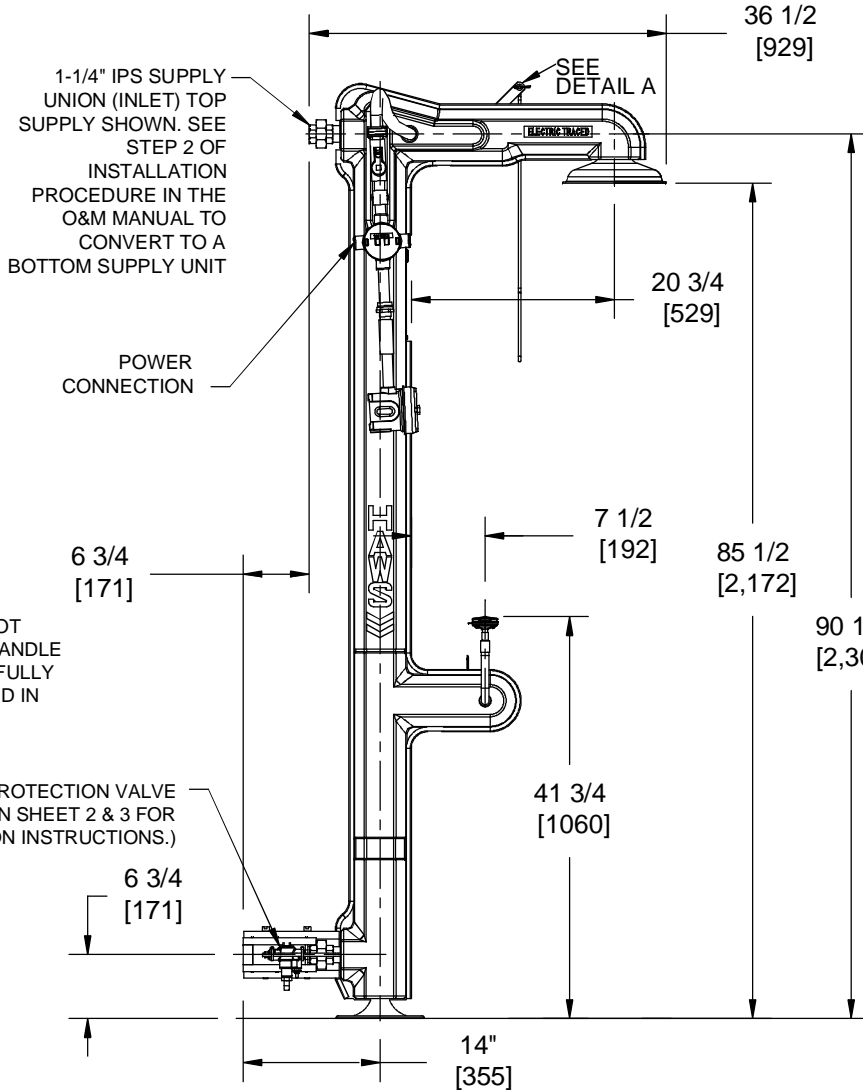

IMPORTANT
SUPPLY MUST BE HEAT TRACED AND INSULATED

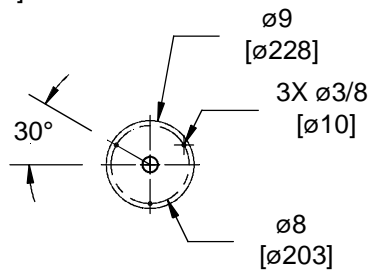

MOUNTING DETAIL B

NOTES:

1. DIMENSIONS IN BRACKETS ARE IN MILLIMETERS.
2. UNLESS OTHERWISE SPECIFIED ALL TOLERANCES TO BE +/- 1/4 INCH.
3. TO COMPLY WITH ANSI Z358.1-2009 FOR EMERGENCY EYE/FACE WASH AND SHOWER EQUIPMENT:
 - UNIT SHALL BE INSTALLED IN ACCORDANCE WITH MANUFACTURER'S INSTRUCTIONS AND ACCEPTABLE PLUMBING PRACTICES.
 - EYE/FACE WASH SHALL BE POSITIONED WITH NOZZLES NOT LESS THEN 83.8 CM (33 IN.) AND NO GREATER THAN 114.3 CM (45 IN.) FROM SURFACE ON WHICH USER STANDS AND 15.3 CM (6 IN.) MINIMUM FROM WALL OR NEAREST OBSTRUCTION.
 - SHOWER SHALL BE POSITIONED SO THAT SHOWER HEAD IS NOT LESS THAN 208.3 CM (82 IN.) NOR MORE THAN 243.8 CM (96 IN.) FROM SURFACE ON WHICH USER STANDS.
 - SHOWER SPRAY PATTERN SHALL HAVE A MINIMUM DIAMETER OF 50.8 CM (20 IN.) AT 152.4 CM (60 IN.) ABOVE SURFACE ON WHICH USER STANDS, AND CENTER OF SPRAY PATTERN SHALL BE LOCATED AT LEAST 40.6 CM (16 IN.) FROM ANY OBSTRUCTION.

(NOTES CONTINUED ON SHEET 2 OF 3.)

		MODEL(S) 8317CTFPC1D1		1455 KLEPPE LANE SPARKS, NEVADA 89431 (775) 359-4712 FAX (775) 359-7424 E-MAIL: HAWS@HAWS.CO.COM WEBSITE: WWW.HAWS.CO.COM	
				PART NUMBER 0002077032.D	
ECN NO. 4140 DRAWN: SLS APPROVED:	REVISED PER BY: ECN: 4888 HM DATE: 7/17/08 DATE:	CHK'D.:		DRAWING NO. 15363A00 REV 9	
SCALE: 1:1		DRAWING TYPE: INSTALLATION		SIZE: A SHEET 1 OF 4	

NOTES: (CONTINUED FROM SHEET 1 OF 4)

4. FREEZE PROTECTION VALVE INSTALLATION INSTRUCTIONS:

- A** INSTALL VALVE SUB-ASSEMBLY INTO FEMALE SECTION OF UNION AND TIGHTEN WATER-TIGHT.
- B** FORM HEAT TRACE CABLE AROUND VALVE AND PLUG, APPLY 2X CABLE-TIES TO HEAT TRACE CABLE, AS SHOWN, ENSURING THAT HEAT TRACE CABLE IS PRESSED FIRMLY AGAINST SIDES OF VALVE (PUSH ANY LOOSE HEAT TRACE CABLE BACK INSIDE JACKET THROUGH RUBBER GROMMET).
- C** SLIDE INNER TUBE W/ PLUGGED END OVER VALVE WITH ADHESIVE SEAM FACING BOTTOM AND NON-PLUGGED END OF TUBE BUTTED UP AGAINST UNION SURFACE. REMOVE 2X ADHESIVE TAPE FROM SEAM AND SQUEEZE ADHESIVE SEAMS TOGETHER AROUND VALVE. APPLY 2X CABLE-TIES TO TUBE, IN APPROXIMATE LOCATIONS SHOWN. TRIM EXCESS CABLE-TIE STRAPPING.

(NOTES CONTINUED ON SHEET 3 OF 4)

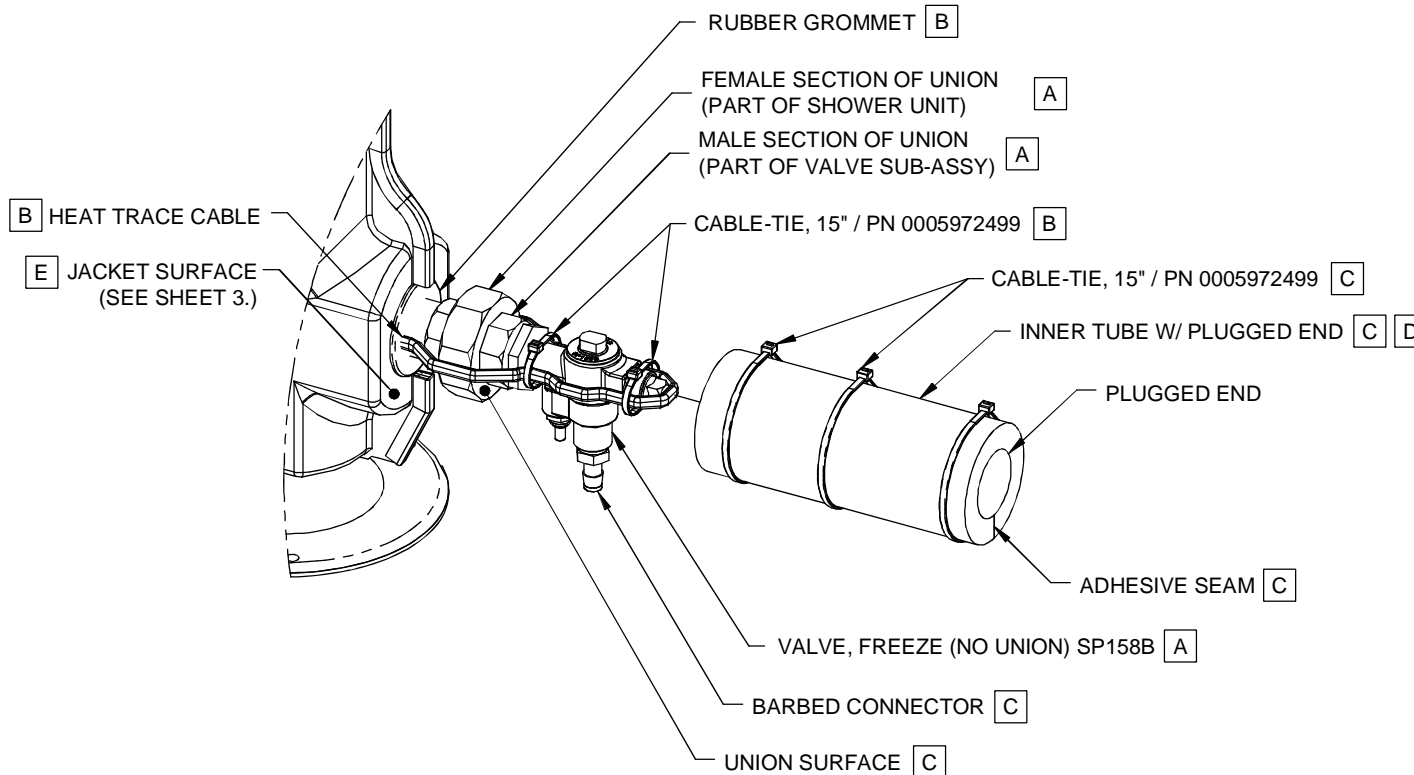

SP158B VALVE SHOWN CONNECTED TO BOTTOM UNION FOR REFERENCE ONLY. VALVE CAN BE INSTALLED AT TOP OR BOTTOM.

		Haws [®]		1455 KLEPPE LANE SPARKS, NEVADA 89431 (775) 359-4712 FAX (755) 359-7424 E-MAIL: HAWS@HAWSCO.COM WEBSITE: WWW.HAWSCO.COM	
				ECN NO: 4632 DRAWN: VWC APPROVED:	REVISED PER: HM DATE: 12/2/12 DATE:
SCALE: NA		DRAWING TYPE: INSTALLATION	SIZE: A	SHEET 2 OF 4	DRAWING NO. 15363A REV 9

NOTES: (CONTINUED FROM SHEET 2 OF 4)

5. FREEZE PROTECTION VALVE INSTALLATION INSTRUCTIONS (CONTINUED):

- D** WRAP OUTER TUBE OVER INNER TUBE ENCAPSULATED VALVE WITH ADHESIVE SEAM ORIENTED PERPENDICULAR TO SEAM OF INNER TUBE. PUSH OUTER TUBE UP AGAINST JACKET SURFACE. WHEN TUBE IS MOUNTED FIRMLY AGAINST JACKET SURFACE, SQUEEZE TUBE AT BARBED CONNECTOR SUCH THAT BARBED NIPPLE PUSHES THROUGH OUTER TUBE WALL. (PUSHING CONNECTOR THROUGH WALL WILL EXTRUDE A CYLINDRICAL PLUG OF TUBING TO BREAK FREE. DISCARD PLUG.) PUSH TUBE DOWN EVEN FURTHER SO THAT HOLE IN TUBE STRETCHES AROUND HEXAGONAL BOSS OF CONNECTOR. SQUEEZE OUTER TUBE TIGHT UNTIL ADHESIVE SEAMS ARE CLOSE ENOUGH TO SEAL. REMOVE PROTECTIVE TAPE AND SEAL SEAMS.
- E** TO ENSURE PROPER INSULATION OF UNION; THERE MUST BE NO SPACE BETWEEN OUTER TUBE AND JACKET SURFACE (SEE SHEET 2 FOR SURFACE CALLOUT). THEREFORE, SLICE TWO PLACES, TOP SIDE AND BOTTOM SIDE, COMPLETELY THROUGH OUTER TUBE TO A LENGTH EQUAL TO DEPTH OF TRIM SEAL. FORCE SLICED TUBE AROUND TRIM SEAL AND PUSH TUBE TIGHTLY AGAINST JACKET, AS SHOWN. APPLY 2X CABLE-TIE HEAD, AND 2X CABLE-TIE STRAP, TO TUBE, IN APPROXIMATE LOCATIONS SHOWN. TRIM EXCESS STRAPPING.

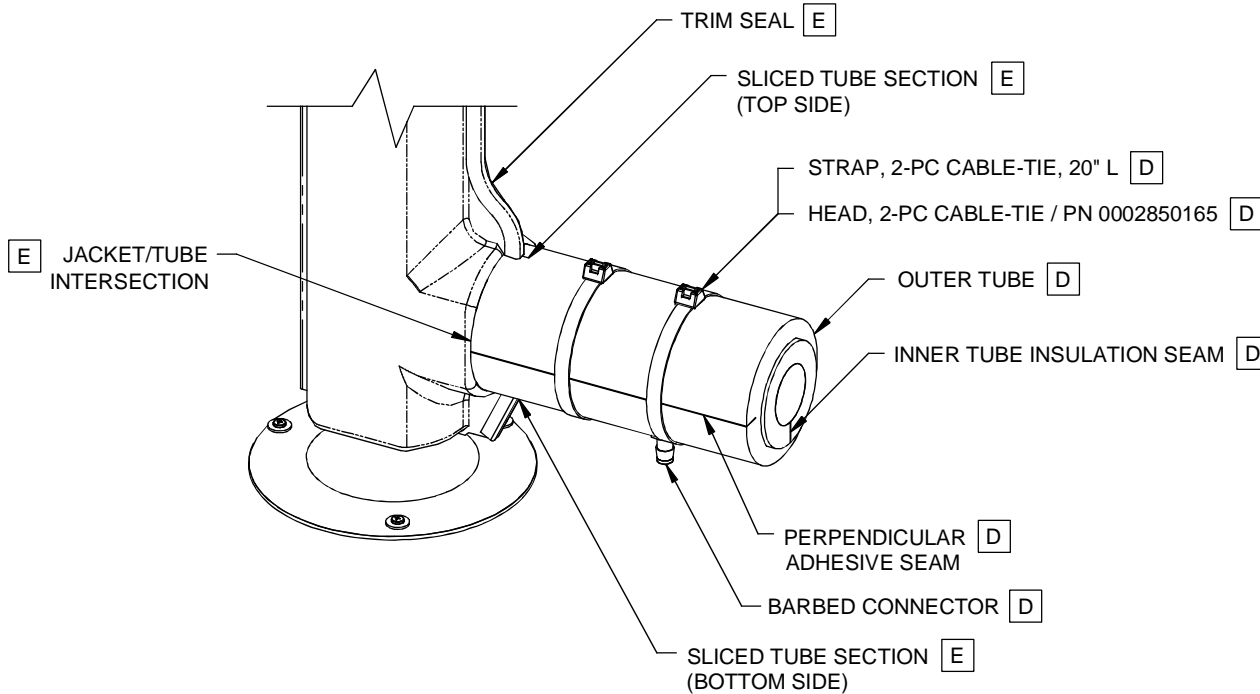

SP158B VALVE SHOWN CONNECTED TO BOTTOM UNION FOR REFERENCE ONLY. VALVE CAN BE INSTALLED AT TOP OR BOTTOM.

		Haws [®]		1455 KLEPPE LANE SPARKS, NEVADA 89431 (775) 359-4712 FAX (755) 359-7424 E-MAIL: HAWS@HAWS.CO.COM WEBSITE: WWW.HAWS.CO.COM	
				ECN NO. 4632 DRAWN: VWC APPROVED:	REVISED PER BY: ECN: 4888 DATE: 12/2/12 DATE:
SCALE: NA			DRAWING TYPE: INSTALLATION		SIZE: A SHEET 3 OF 4

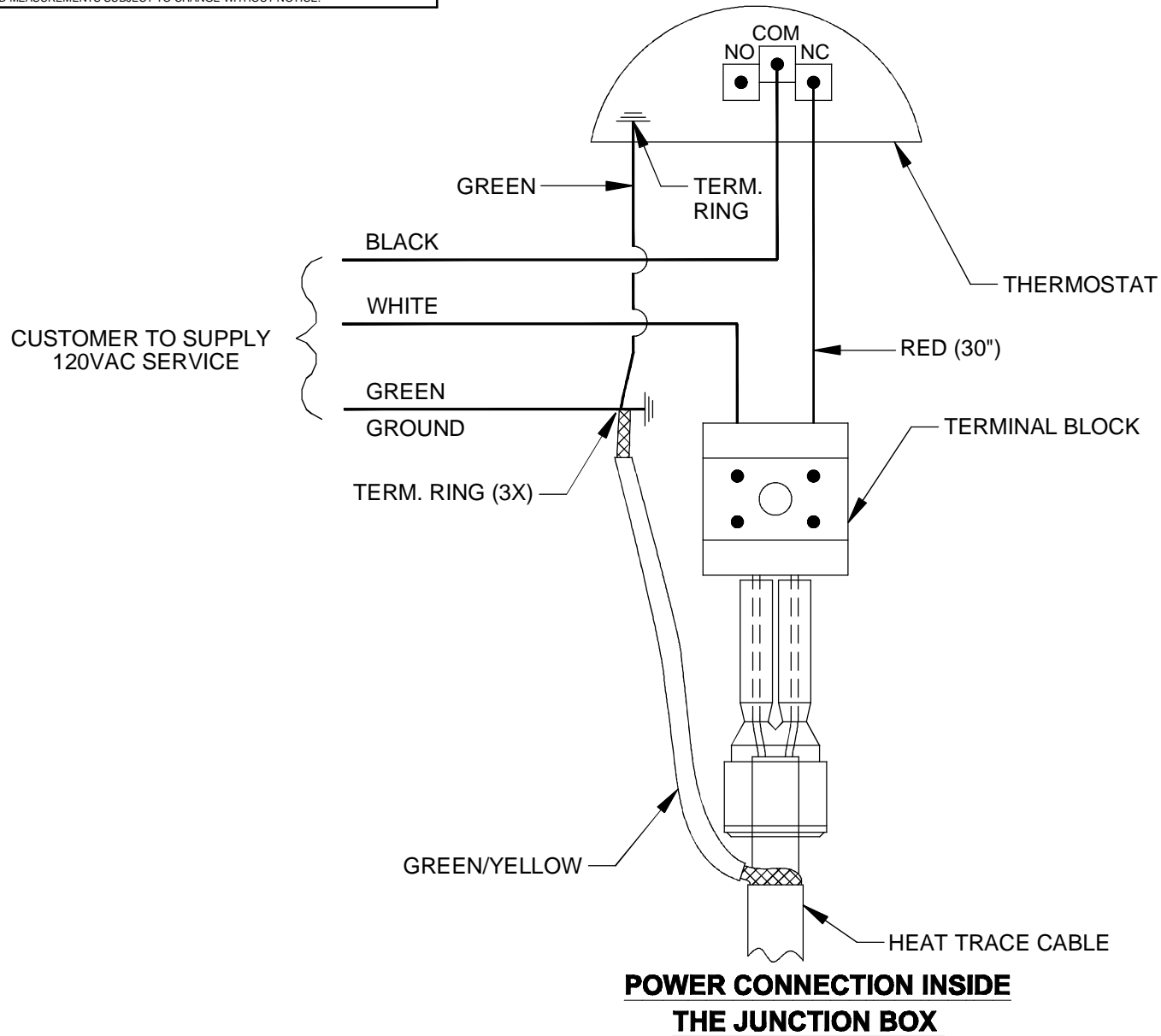

ELECTRICAL SCHEMATIC



1455 KLEPPE LANE
SPARKS, NEVADA 89431
(775) 359-4712 FAX (755) 359-7424
E-MAIL: HAWS@HAWSCO.COM
WEBSITE: WWW.HAWSCO.COM

ECN NO. 4140	REVISED PER ECN: 4888	BY: HM	MODEL(S)	PART NUMBER
DRAWN: SLS	DATE: 7/17/08	CHKD.:	8317CTFPC1D1	0002077032.D
APPROVED:	DATE:			DRAWING NO. 15363A00
			SCALE: 1:1	REVISION 9
			DRAWING TYPE: INSTALLATION	SIZE: A SHEET 4 OF 4