

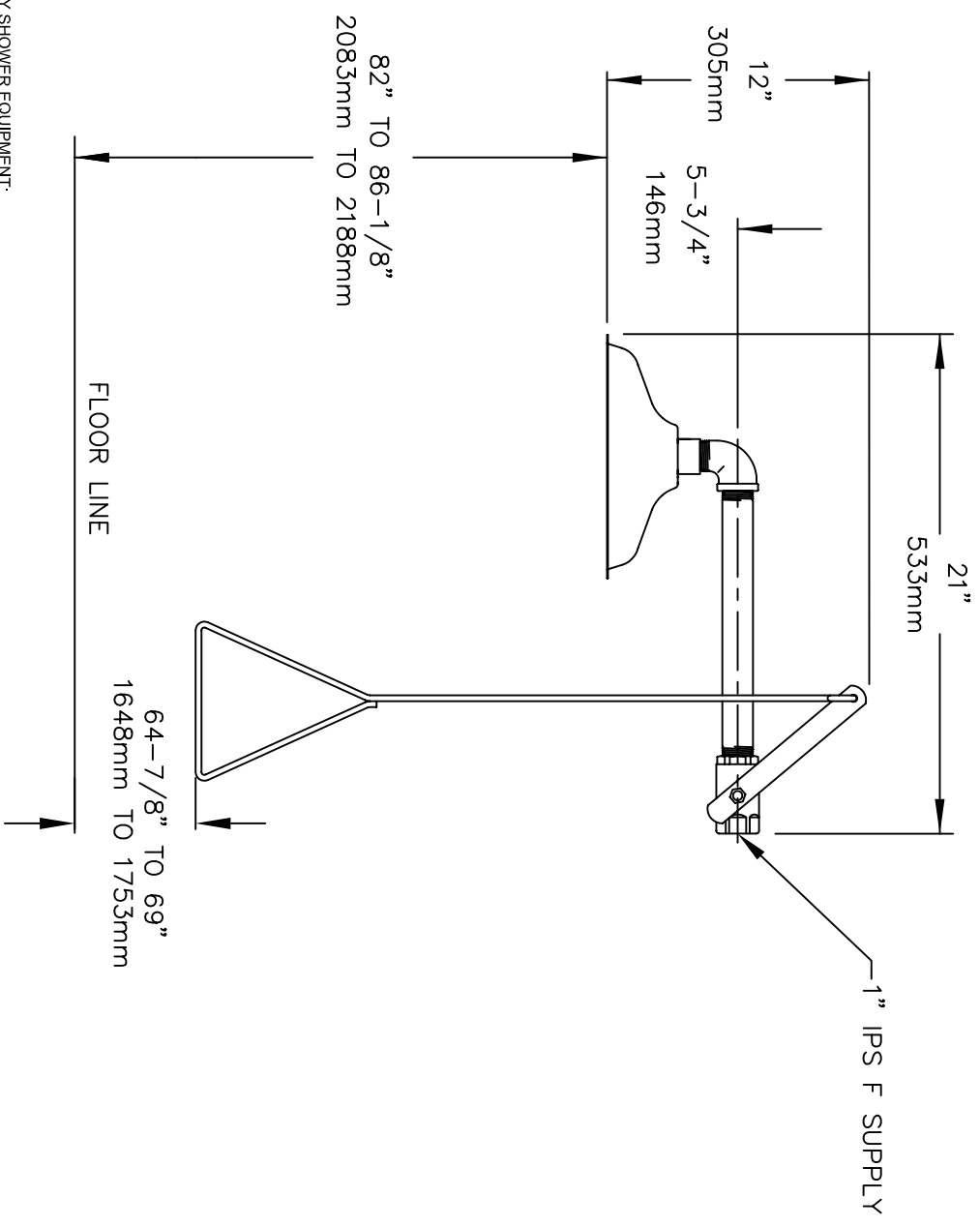

HORIZONTAL SUPPLY (STANDARD)



NOTES:

1. TO COMPLY WITH ANSI Z358.1-2009 FOR EMERGENCY SHOWER EQUIPMENT:
 - UNIT SHALL BE INSTALLED IN ACCORDANCE WITH MANUFACTURER'S INSTRUCTIONS AND ACCEPTABLE PLUMBING PRACTICES.
 - SHOWER SHALL BE POSITIONED SO THAT SHOWER HEAD IS NOT LESS THAN 208.3 CM (82 IN.) NOR MORE THAN 243.8 CM (96 IN.) FROM SURFACE ON WHICH USER STANDS.
 - SHOWER SPRAY PATTERN SHALL HAVE A MINIMUM DIAMETER OF 50.8 CM (20 IN.) AT 152.4 CM (60 IN.) ABOVE SURFACE ON WHICH USER STANDS, AND CENTER OF SPRAY PATTERN SHALL BE LOCATED AT LEAST 40.6 CM (16 IN.) FROM ANY OBSTRUCTION.
2. DIMENSIONS MAY VARY ±1/2" [12.7mm].

				1455 KLEPPE LANE SPARKS, NEVADA 89431 (775) 359-4712 FAX (775) 359-7424 EMAIL: HAWS@HAWSCO.COM WEBSITE: WWW.HAWSCO.COM	
EQUIP. NO.:	REVISED PER BY:	MODEL(S)			
DRAWN:	CHK'D:	8123	EMERGENCY SHOWER		
DATE:	DATE:		SCALE: 1/8" = 1"		
APPROVED:	DATE:		DRAWING TYPE: INSTALLATION		
			SIZE: A	SHEET: 1	OF 2
			PART NUMBER:	0002080120.D	
			DRAWING NO.:	09470A00	REV:
				13	

FOR VERTICAL SUPPLY (RECONFIGURE AS SHOWN)

REMOVE ELBOW AND PIPE FROM ASSEMBLY

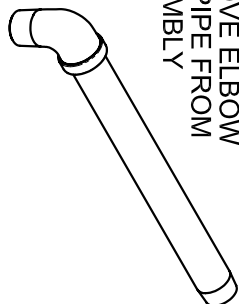

REMOVE HANDLE, FLIP COMPLETELY TO OTHER SIDE. REATTACH.

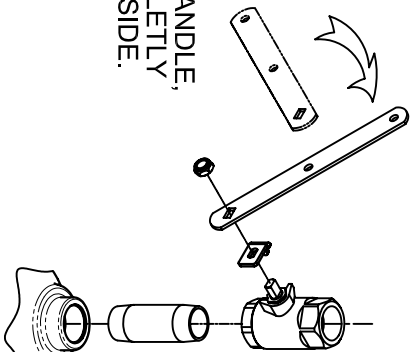

ASSEMBLE SHORTER 3-1/2" LONG NIPPLE (SUPPLIED)

SHOWER HEAD

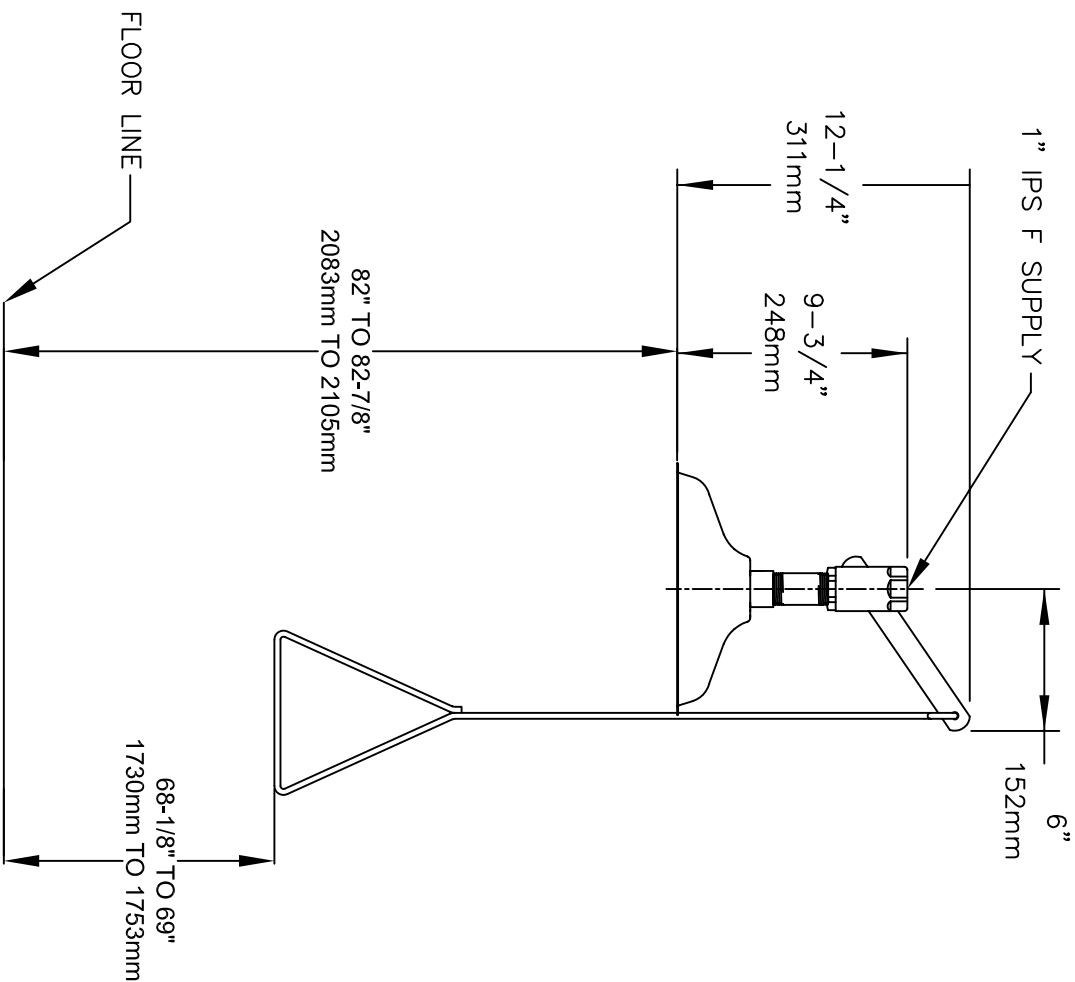

NOTES:

- TO COMPLY WITH ANSI Z358.1-2009 FOR EMERGENCY SHOWER EQUIPMENT:
 - UNIT SHALL BE INSTALLED IN ACCORDANCE WITH MANUFACTURER'S INSTRUCTIONS AND ACCEPTABLE PLUMBING PRACTICES.
 - SHOWER SHALL BE POSITIONED SO THAT SHOWER HEAD IS NOT LESS THAN 208.3 CM (82 IN.) NOR MORE THAN 243.8 CM (96 IN.) FROM SURFACE ON WHICH USER STANDS.
 - SHOWER SPRAY PATTERN SHALL HAVE A MINIMUM DIAMETER OF 50.8 CM (20 IN.) AT 152.4 CM (60 IN.) ABOVE SURFACE ON WHICH USER STANDS, AND CENTER OF SPRAY PATTERN SHALL BE LOCATED AT LEAST 40.6 CM (16 IN.) FROM ANY OBSTRUCTION.

2. DIMENSIONS MAY VARY ±1/2" [12.7mm].

		1455 KLEPPE LANE SPARKS, NEVADA 89431 (775) 359-4712 FAX (775) 359-7424 EMAIL: HAWS@HAWS.CO.COM WEBSITE: WWW.HAWS.CO.COM	
EQN NO. REVISED PER BY:	MODEL(S)	PART NUMBER:	
DRAWN: ECK, 4531 IR	8123	0002080120.D	
DATE: 5/13	EMERGENCY SHOWER	DRAWING NO.:	REV:
APPROVED: [Signature]	SCALE: 1/8"	09470A00	13
DATE:	DRAWING TYPE: INSTALLATION	SIZE: A	SHEET: 2 OF 2