



AXION® MSR Floor Mount Emergency Drench Shower

model 8100

FEATURES & BENEFITS

CONSTRUCTION

1-1/4" IPS Schedule 40 hot-dipped galvanized steel pipe and fittings along with powder-coated cast-iron 9" (22.9 cm) diameter floor flange provide corrosion resistance in a long lasting product.

QUALITY CONTROL

Valve assembly is pre-built for reduced installation time and an added peace of mind for the installer.

VALVES

Valve is designed so the full flow of water remains on with the simple tug of the triangular pull rod. Unit also comes equipped with a stainless steel ball and stem to provide added protection against corrosion and breakage.

SHOWER HEAD

AXION® MSR ABS plastic drench showerhead uses a hydrodynamic design to give equal distribution of water throughout the entire footprint of flow.

SAFETY

8" x 10-3/4" (20.3 x 27.3 cm) universal emergency sign and 21" (53.3 cm) self-adhesive high visibility stripe in Safety Green and bright yellow make the 8100 easily detected in an emergency. Test card to record weekly checks helps maintain the unit's best working quality.

PULL ROD

28" (71.1 cm) stainless steel triangular pull rod provides a reachable height for users while maintaining its durable design.



SPECIFICATIONS

Model 8100 floor mounted drench shower shall include the AXION® MSR hydrodynamic designed ABS plastic showerhead with self-regulating flow control, and chrome-plated brass stay-open ball valve equipped with a stainless steel ball and stem. Unit shall also include powder-coated cast-iron 9" (22.9 cm) diameter floor flange, self-adhesive high visibility 21" (53.3 cm) long stripe in Safety Green and bright yellow, stainless steel pull rod with triangular handle, universal sign, and 1-1/4" IPS supply.

OPTIONS

- Test Tag: SP170 is a green waterproof test card with space for date and initials of inspector. Used to record weekly testing of emergency equipment.
- Emergency Body Spray Kit: Model 8901RFK, body spray unit with ABS plastic head, stay open squeeze lever valve, 8 foot (243.8 cm) hose, and installation kit.
- AXION® MSR Showerhead: Model SP829SS, AXION® MSR stainless steel drench showerhead with integral 20 gpm (75.7 L) flow control.
- Thermostatic Mixing Valve: Model 9201E AXION® Emergency Tempering Valve thermostatically mixes hot and cold water to provide a safe fluid supply for emergency showers and eyewash equipment, with a flow rate of 31 gpm (117.3 L).

To see all options for this model, visit www.hawscos.com

APPLICATIONS

Where the body of any person may be exposed to injurious or corrosive materials, suitable facilities for quick drenching and cleansing of the body shall be provided within the work area for immediate emergency use. Emergency deluge showers shall be in unobstructed and accessible locations that require no more than 10 seconds for the injured person to reach. Model 8100 is certified by CSA to meet the ANSI Z358.1 Standard for Emergency Eyewash and Shower Equipment.



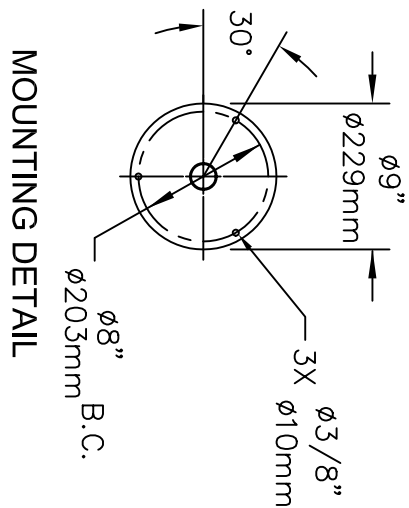
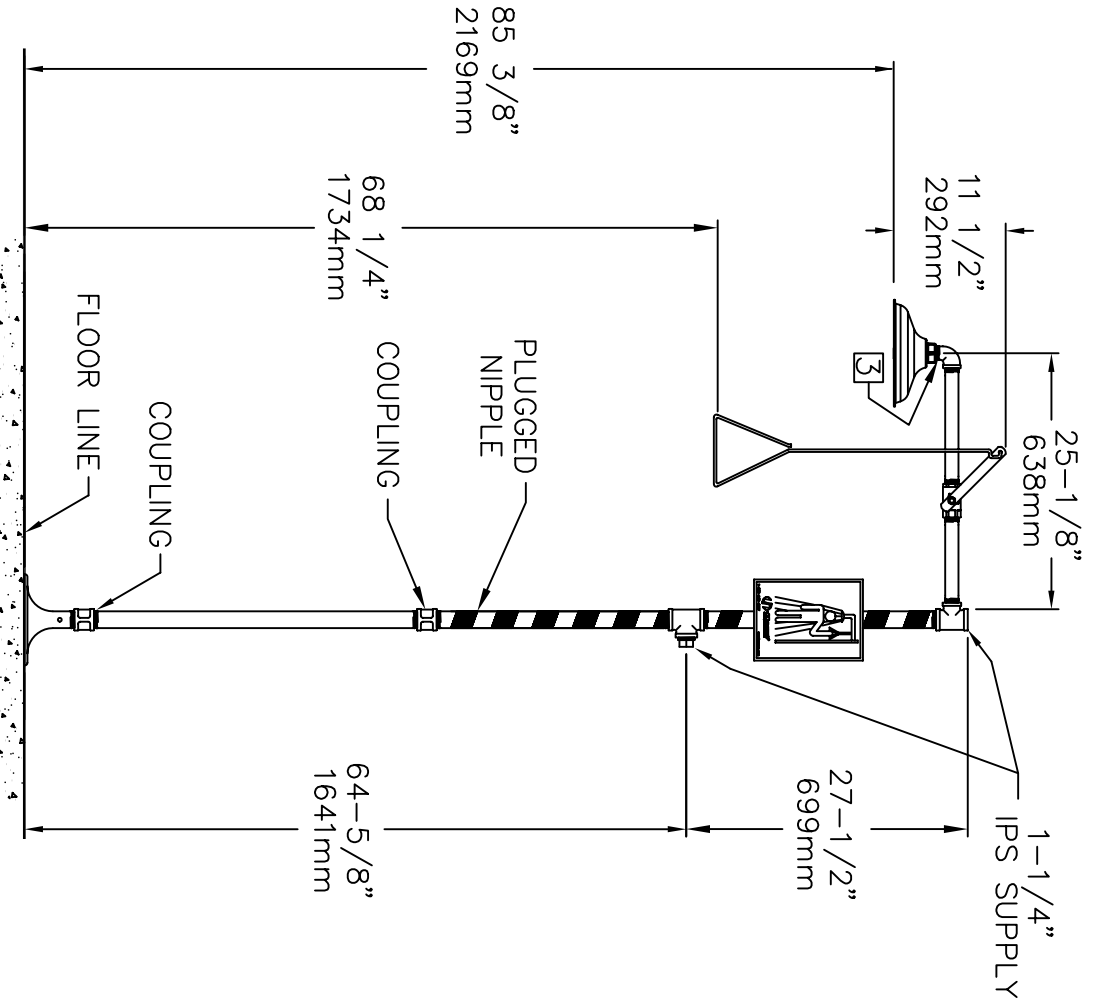

NOTES:

- DIMENSIONS MAY VARY BY ± 1/2 INCH (13mm).
- TO COMPLY WITH ANSI Z368.1-2009 FOR EMERGENCY SHOWER EQUIPMENT:
 - UNIT SHALL BE INSTALLED IN ACCORDANCE WITH MANUFACTURER'S INSTRUCTIONS AND ACCEPTABLE PLUMBING PRACTICES.
 - SHOWER SHALL BE POSITIONED SO THAT SHOWER HEAD IS NOT LESS THAN 208.3 CM (82 IN.) NOR MORE THAN 243.8 CM (96 IN.) FROM SURFACE ON WHICH USER STANDS.
 - SHOWER SPRAY PATTERN SHALL HAVE A MINIMUM DIAMETER OF 50.8 CM (20 IN.) AT 152.4 CM (60 IN.) ABOVE SURFACE ON WHICH USER STANDS, AND CENTER OF SPRAY PATTERN SHALL BE LOCATED AT LEAST 40.6 CM (16 IN.) FROM ANY OBSTRUCTION.
- DO NOT USE REGULAR PIPE SEALANT. IF NECESSARY USE DOW CORNING 832 SEALANT PLACING 5 SMALL BEADS ON THE MALE THREADS, JUST ABOVE THE FIRST THREAD.

		1455 KLEPPE LANE SPARKS, NEVADA 89431 (775) 359-4712 FAX (775) 359-7424 E-MAIL: HAWS@HAWS.CO.COM WEBSITE: WWW.HAWS.CO.COM	
EQ# NO.:	78385768	DATE:	08/9/11
DATE:	08/9/11	DATE:	08/9/11
MODELS:	8100 DRENCH SHOWER	DATE:	08/9/11
INFO FAX DOC #:	28100	DATE:	08/9/11
INSTALLATION INSTRUCTIONS:	INSTALLATION INSTRUCTIONS	DATE:	08/9/11
DATE:	08/9/11	DATE:	08/9/11
DATE:	08/9/11	DATE:	08/9/11
DATE:	08/9/11	DATE:	08/9/11
DATE:	08/9/11	DATE:	08/9/11
DATE:	08/9/11	DATE:	08/9/11
DATE:	08/9/11	DATE:	08/9/11
DATE:	08/9/11	DATE:	08/9/11
DATE:	08/9/11	DATE:	08/9/11