

7610 DECK MOUNTED CONFIGURATION (SEE SHEET 2 FOR 7610 WALL MOUNTED CONFIGURATION)

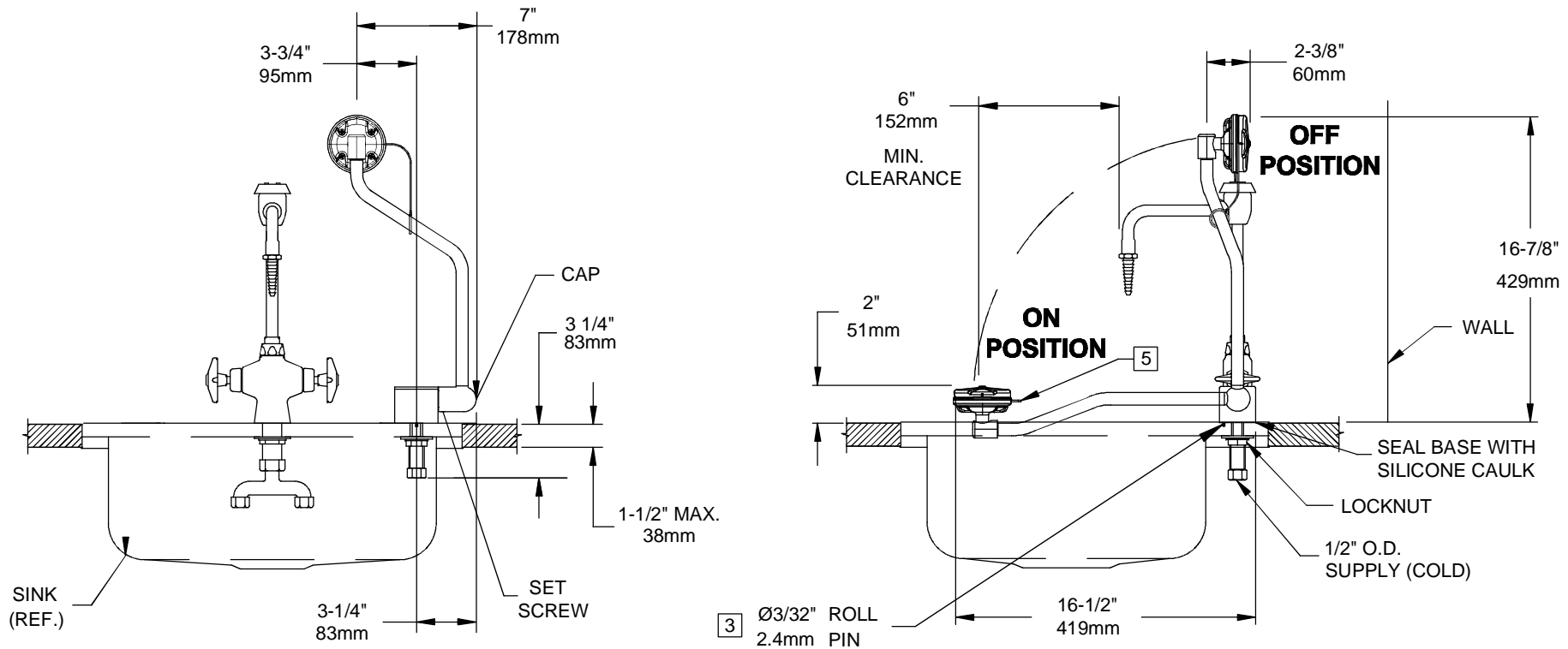

NOTES:

1. WHEN INSTALLING THIS UNIT, LOCAL, STATE, OR FEDERAL CODES SHOULD BE ADHERED TO FOR INSTALLATION DIMENSIONS (LOCATIONS), WASTE AND SUPPLY REQUIREMENTS OTHER THAN SHOWN.
2. THE ANSI Z358.1-2009 STANDARD SPECIFIES EYEWASH NOZZLE HEIGHTS TO BE 83.8cm (33 IN.) TO 114.3cm (45 IN.) ABOVE THE FLOOR AND 15.3cm (6 IN.) MINIMUM FROM WALL OR NEAREST OBSTRUCTION.
3. DRILL ONE Ø7/8" [22mm] HOLE AND ONE Ø3/32" HOLE WHERE UNIT IS TO BE INSTALLED. REFER TO MOUNTING HOLE DETAIL.
4. THESE DIMENSIONS MAY VARY ±1/2" [6.4mm].
5. ASSEMBLE EYE/FACE WASH TO ARM, ORIENT TAB ON ASSEMBLY AWAY FROM USER.

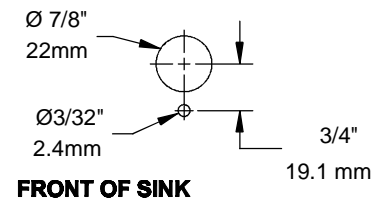

3 MOUNTING HOLE DETAIL

		Haws [®]		1455 KLEPPE LANE SPARKS, NEVADA 89431 (775) 359-4712 FAX (775) 359-7424 E-MAIL: HAWS@HAWSCO.COM WEBSITE: WWW.HAWSCO.COM	
				MODEL(S) 7610 PULLDOWN EYE/FACE WASH	
ECN NO. 2066 DRAWN: JF APPROVED: FV	REVISED PER: ECN: 5005 DATE: 10/96 DATE: 06/25/15	BY: HM CHK'D: RVH	SCALE: 1:1 DRAWING TYPE: INSTALLATION SIZE: A SHEET 1 OF 2		
REVISION 14				REVISION 14	

7610 WALL MOUNTED CONFIGURATION (SEE SHEET 1 FOR 7610 DECK MOUNTED CONFIGURATION)

CONVERT TO WALL MOUNT CONFIGURATION

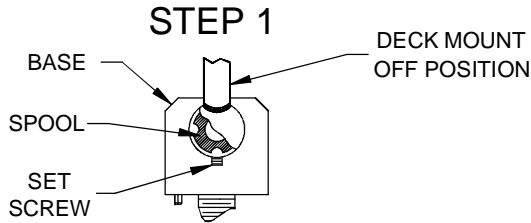

UNIT IS SHIPPED IN DECK MOUNT CONFIGURATION. TO CONVERT TO WALL MOUNT CONFIGURATION, POSITION ARM IN "DECK MOUNT OFF POSITION" AS ABOVE.

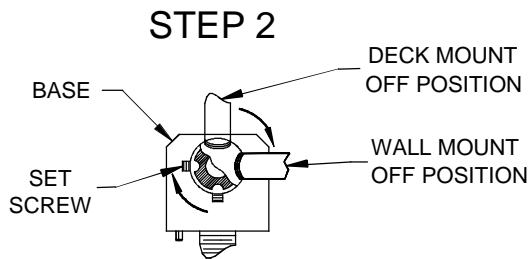

NOTE DEPTH OF SET SCREW PRIOR TO LOOSENING. LOOSEN SET SCREW AND ROTATE EYEWASH ARM 90 DEGREES CLOCKWISE (AS SHOWN) WHILE MAKING SURE TO NOT ROTATE THE SPOOL. RETIGHTEN SET SCREW IN NEW POSITION. ENSURE SET SCREW IS PROPERLY SEATED IN THE INDENT. MAKE SURE THE SET SCREW IS TIGHT AND AT ITS ORIGINAL DEPTH. ENSURE CORRECT ARM ORIENTATION BEFORE MOUNTING TO WALL. REFERENCE DRAWINGS AT RIGHT.

NOTES:

1. WHEN INSTALLING THIS UNIT, LOCAL, STATE, OR FEDERAL CODES SHOULD BE ADHERED TO FOR INSTALLATION DIMENSIONS (LOCATIONS), WASTE AND SUPPLY REQUIREMENTS OTHER THAN SHOWN.
2. THE ANSI Z358.1-2009 STANDARD SPECIFIES EYEWASH NOZZLE HEIGHTS TO BE 83.8cm (33 IN.) TO 114.3cm (45 IN.) ABOVE THE FLOOR AND 15.3cm (6 IN.) MINIMUM FROM WALL OR NEAREST OBSTRUCTION.
- 3 DRILL ONE $\varnothing 7/8"$ [22mm] HOLE AND ONE $\varnothing 3/32"$ HOLE WHERE UNIT IS TO BE INSTALLED. REFER TO MOUNTING HOLE DETAIL.
4. THESE DIMENSIONS MAY VARY $\pm 1/2"$ [6.4mm].
- 5 ASSEMBLE EYE/FACE WASH TO ARM, ORIENT TAB ON ASSEMBLY AWAY FROM USER.

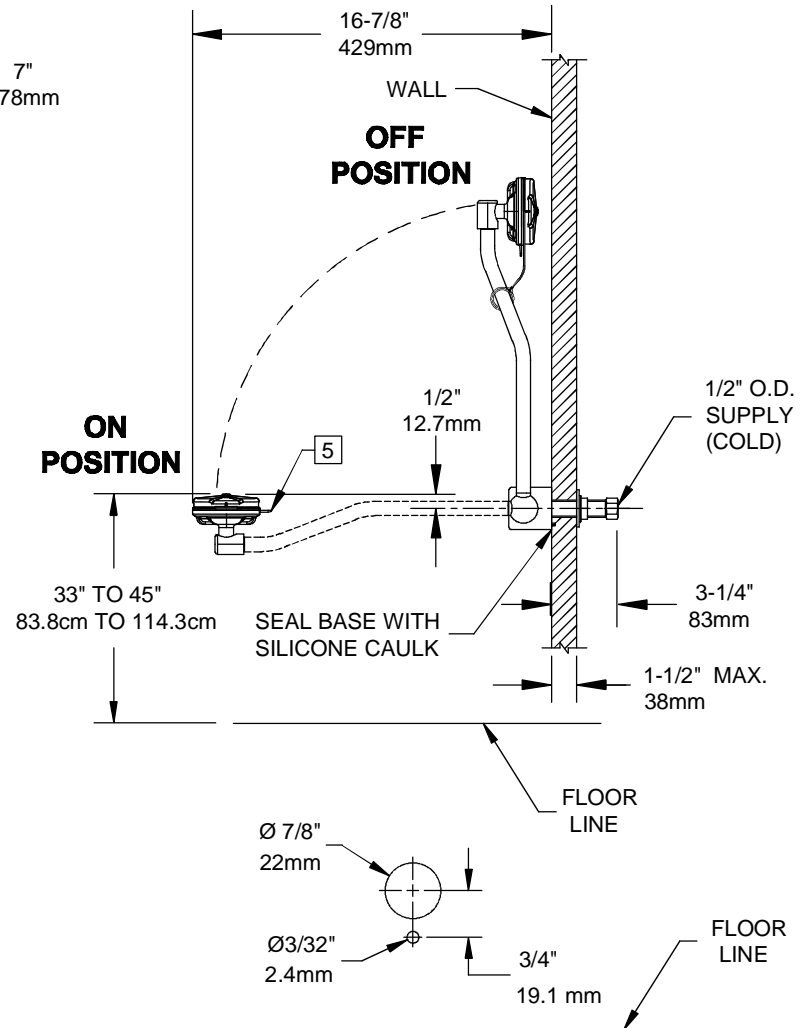
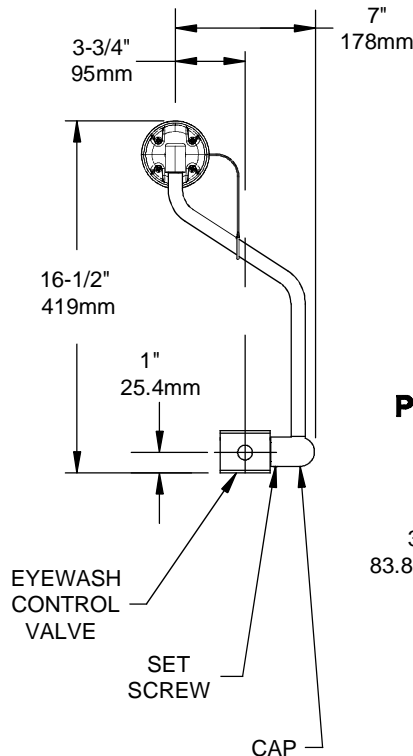

3 MOUNTING HOLE DETAIL

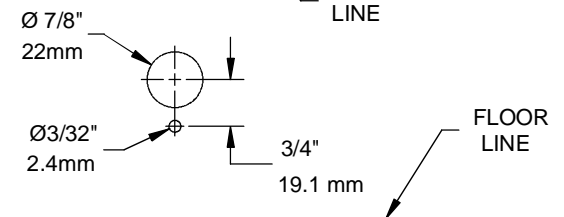

		1455 KLEPPE LANE SPARKS, NEVADA 89431 (775) 359-4712 FAX (775) 359-7424 E-MAIL: HAWS@HAWSCO.COM WEBSITE: WWW.HAWSCO.COM	
ECN NO. 2066 DRAWN: JF APPROVED: FV	REVISED PER: ECN: 5005 DATE: 10/96 DATE: 06/25/15	BY: HM CHK'D: RVH	MODEL(S) 7610 PULLDOWN EYE/FACE WASH
SCALE: 1:1 DRAWING TYPE: INSTALLATION SIZE: A			PART NUMBER: 0002080067.D REVISION: 14 SHEET 2 OF 2