



# model 7602.15

Portable Emergency Eyewash

## FEATURES & BENEFITS

### CONSTRUCTION

Stainless steel constructed tank makes for a solid portable unit with added resistance against corrosion and breakage.

### ADDED PROTECTION/MISC.

Green polyethylene plastic dust covers that release with water pressure keep the unit protected from debris up until the last second before use further optimizing operation.

### VALVES

Valve comes equipped with stainless steel ball and stem for added protection against corrosion and breakage. Full continuous flow occurs with the simple push of a stainless steel flag.

### SAFETY

Air pressure gauge, pressure relief valve, and fire-type air fill valve decrease the possibility of mishaps and make for a safer piece of emergency equipment.

### FLOW CONTROLS

Green ABS plastic Soft-Flo anti-surge heads distribute water at a rate of .25 gpm (.9 L) when pressure is between 30 and 90 psi (2.1 and 6.2 bar). Combine this with capabilities of a 15 gallon (56.8 L) portable and the irrigation process is a thorough one.



## SPECIFICATIONS

Model 7602.15, pressurized portable emergency eyewash shall include a 15 gallon (56.8 L) stainless steel container equipped with pressure gauge and safety relief valve, soft-flo ABS plastic eyewash anti-surge heads with integral flow controls and dust covers, chrome plated brass stay-open 1/2" IPS eyewash valve with stainless steel ball and valve stem, with large stainless push handle activation. Additive not included - Order separately.

## OPTIONS

- ❑ Water Additive: Model 9082, 'sterile' bacteriostatic preservative for use in portable eyewash stations. One 5 oz. (148 ml) bottle will preserve 5 to 20 gallons (18.9 to 75.7 L) of potable water for up to three months. Four bottles per carton.
- ❑ Emergency Body Spray: Model 8901B, wall-mounted body spray with 8 foot (243.8 cm) pressure rated hose, including wall mounting bracket.
- ❑ Transport Cart: Model 9008 cart designed to transport all stainless steel portable eyewashes.

To see all options for this model, visit [www.hawesco.com](http://www.hawesco.com)

## APPLICATIONS

Where the eyes of any person may be exposed to injurious or corrosive materials, when suitable facilities for quick flushing of the eyes needs to be provided and a continuous supply of water is not available. Although the 7602.15 may be used in a wide variety of locations, it is ideal for the remote and low traffic areas where protective and mobile measures may still be needed. Emergency eyewash facilities shall be in unobstructed and accessible locations that require no more than 10 seconds for the injured person to reach. Model 7602.15 is certified by CSA to meet the ANSI Z358.1 Standard for Emergency Eyewash and Shower Equipment.



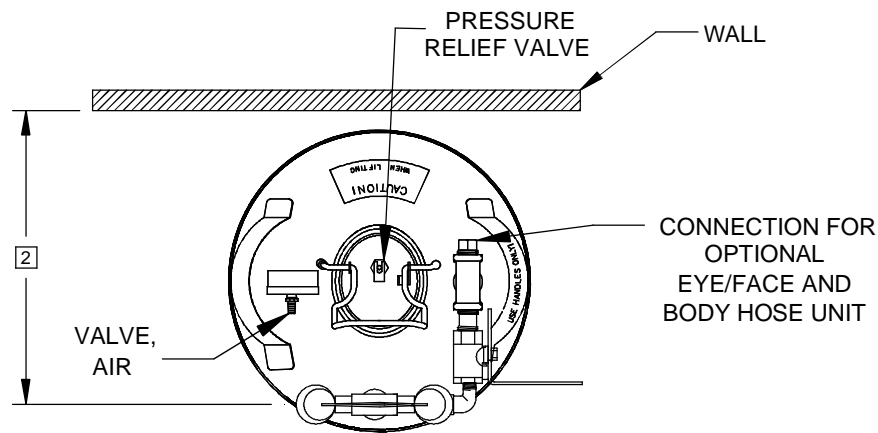

TOP VIEW

**NOTES:**

1 TO COMPLY WITH ANSI Z358.1-2014 FOR EMERGENCY EYEWASH:

UNIT SHALL BE INSTALLED IN ACCORDANCE WITH MANUFACTURER'S INSTRUCTIONS AND ACCEPTABLE PLUMBING PRACTICES.

EYEWASH SHALL BE POSITIONED WITH NOZZLES NOT LESS THAN 83.8 CM (33 IN.) AND NO GREATER THAN 114.3 CM (45 IN.) FROM SURFACE ON WHICH USER STANDS AND 15.3 CM (6 IN.) MINIMUM FROM WALL OR NEAREST OBSTRUCTION.

2 EYEWASH HEAD ASSEMBLY MUST BE PARALLEL TO WALL OR OBSTRUCTION TO MEET CRITERIA STATED IN ACCORDANCE TO NOTE 1.

\* 3. DIMENSIONS MAY VARY ±1/2" [12.7mm].

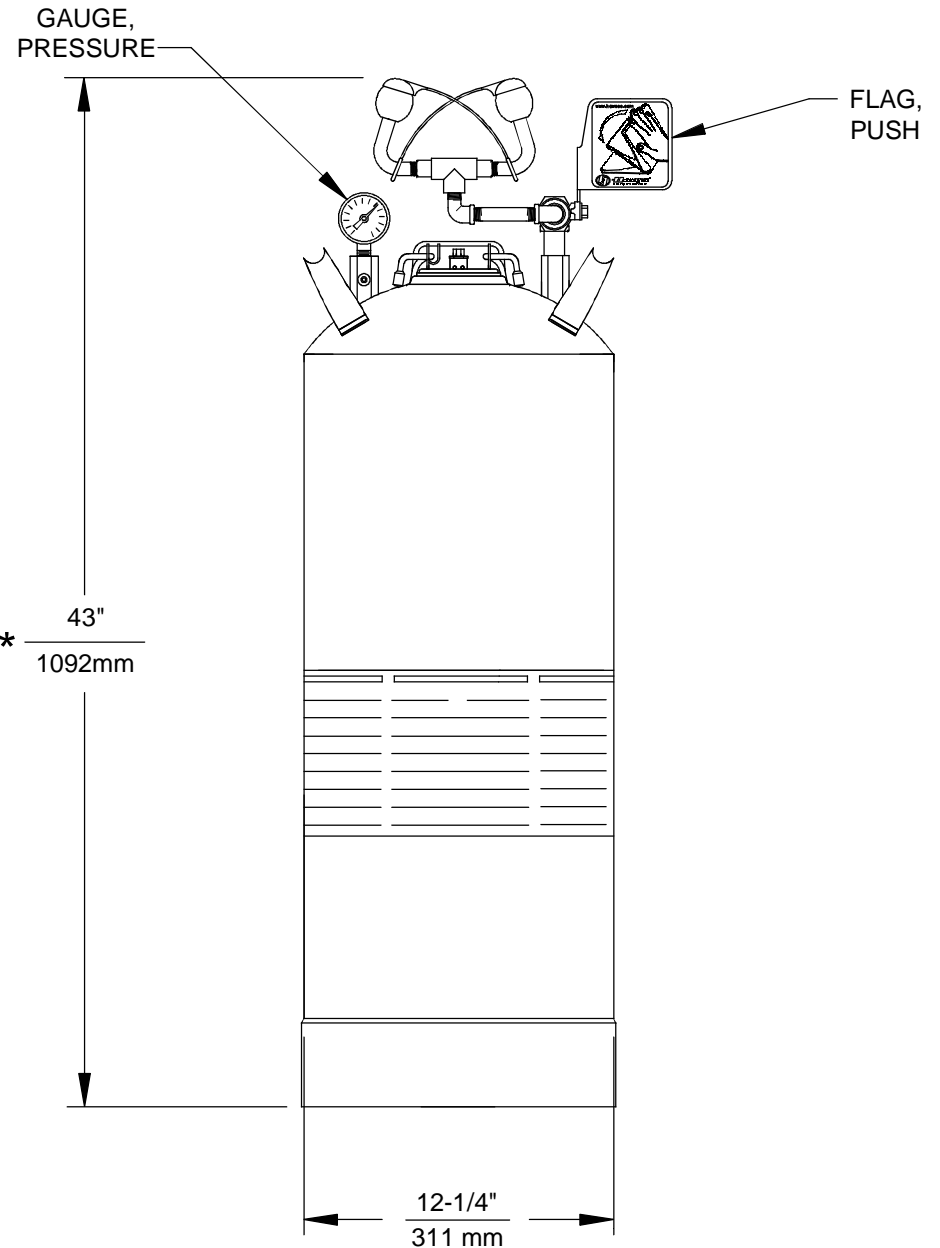

**Haws**®

1455 KLEPPE LANE  
SPARKS, NEVADA 89431  
(775) 359-4712 FAX (775) 359-7424  
E-MAIL: HAWS@HAWS.CO.COM  
WEBSITE: WWW.HAWS.CO.COM

ECN NO.:	REVISED PER BY:	MODEL(S)	PART NUMBER
ECN: 4967	HM	7602.15	0002080053.D
DRAWN:	DATE:	CHK'D.:	REVISION
DZ	2/98	RVH	14
APPROVED:	DATE:	SCALE:	DRAWING TYPE:
FV	06/17/15	1:8	INSTALLATION
		SIZE:	SHEET 1 OF 1