

DO NOT EXCEED WATER FILL LINE. REFER TO INSTALLATION INSTRUCTIONS IN "OPERATION AND MAINTENANCE MANUAL" FOR PROPER FILLING PROCEDURES.

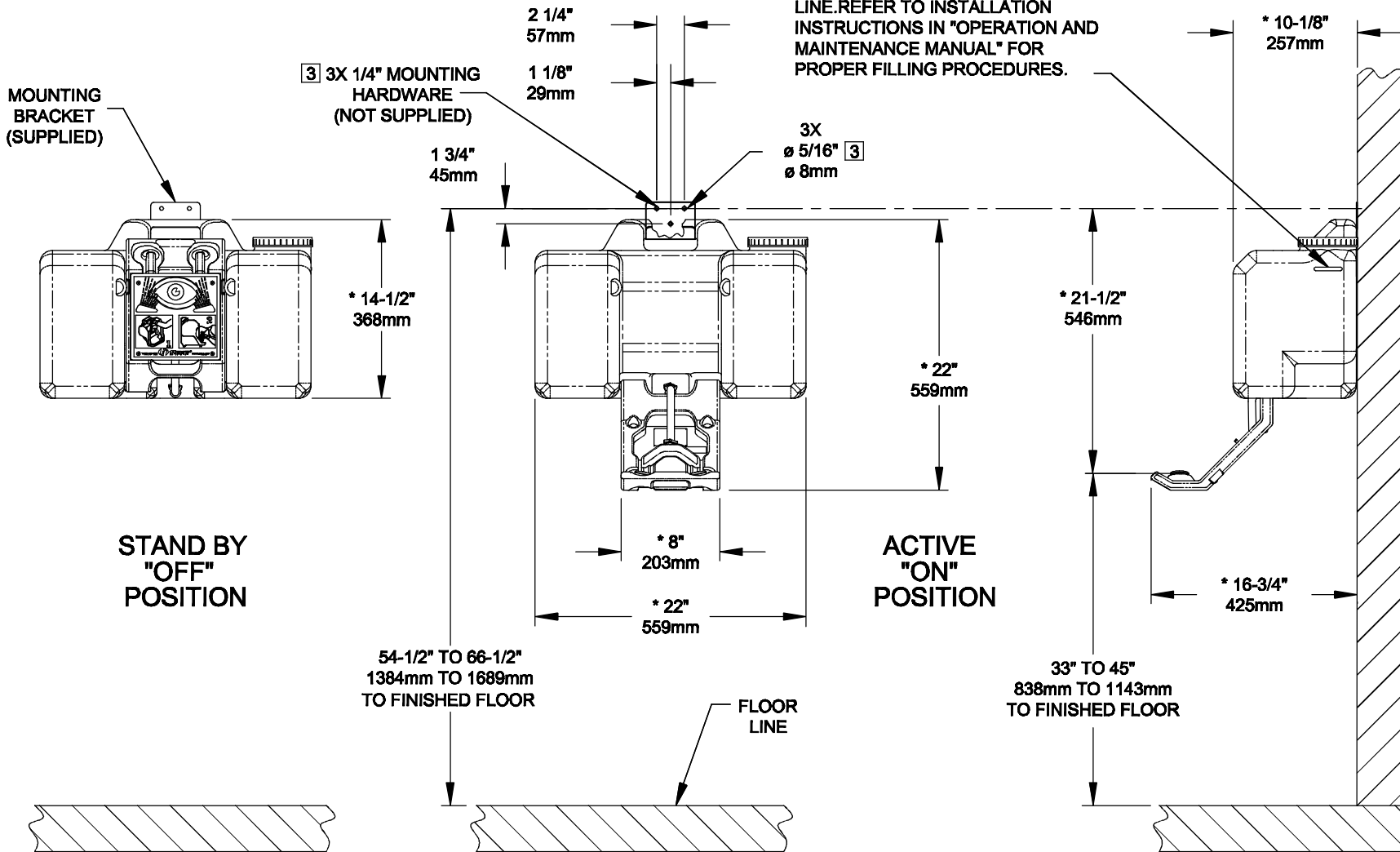

NOTES:

- TO COMPLY WITH ANSI Z358.1-2009 FOR EMERGENCY EYEWASH OR EYE/FACE WASH AND SHOWER EQUIPMENT:
 - UNIT SHALL BE INSTALLED IN ACCORDANCE WITH MANUFACTURER'S INSTRUCTIONS AND ACCEPTABLE PLUMBING PRACTICES.
 - EYEWASH OR EYE/FACE WASH SHALL BE POSITIONED WITH NOZZLES NOT LESS THAN 83.8 CM (33 IN.) AND NO GREATER THAN 114.3 CM (45 IN.) FROM SURFACE ON WHICH USER STANDS AND 15.3 CM (6 IN.) MINIMUM FROM WALL OR NEAREST OBSTRUCTION.
- UNIT MUST BE LEVEL FROM FRONT TO BACK AND SIDE TO SIDE.
- ALL THREE MOUNTING HOLES ON MOUNTING-BRACKET MUST BE USED TO PROPERLY SECURE EYEWASH UNIT TO WALL.
- *DIMENSIONS MAY VARY ±1/2" [12.7mm].

MODEL 7501 (SHOWN)
MODEL 7501FP - WITH HEATER (SEE SHEET 2 OF 3)

		1455 KLEPPE LANE SPARKS, NEVADA 89431 (775) 359-4712 FAX (775) 359-7424 E-MAIL: HAWS@HAWSO.COM WEBSITE: WWW.HAWSO.COM	
		ECN NO. REVISED PER BY: ECN: 4742 HM	MODEL(S) 7501 / 7501FP PORTABLE EYEWASH
DRAWN: RTM	DATE: 5/19/04	CHKD.: HM	DRAWING NO. 15153A00
APPROVED: DATE:	SCALE: 1:12	DRAWING TYPE: INSTALLATION	REV 11 SHEET 1 OF 3

DO NOT EXCEED WATER FILL LINE. REFER TO INSTALLATION INSTRUCTIONS IN "OPERATION AND MAINTENANCE MANUAL" FOR PROPER FILLING PROCEDURES.

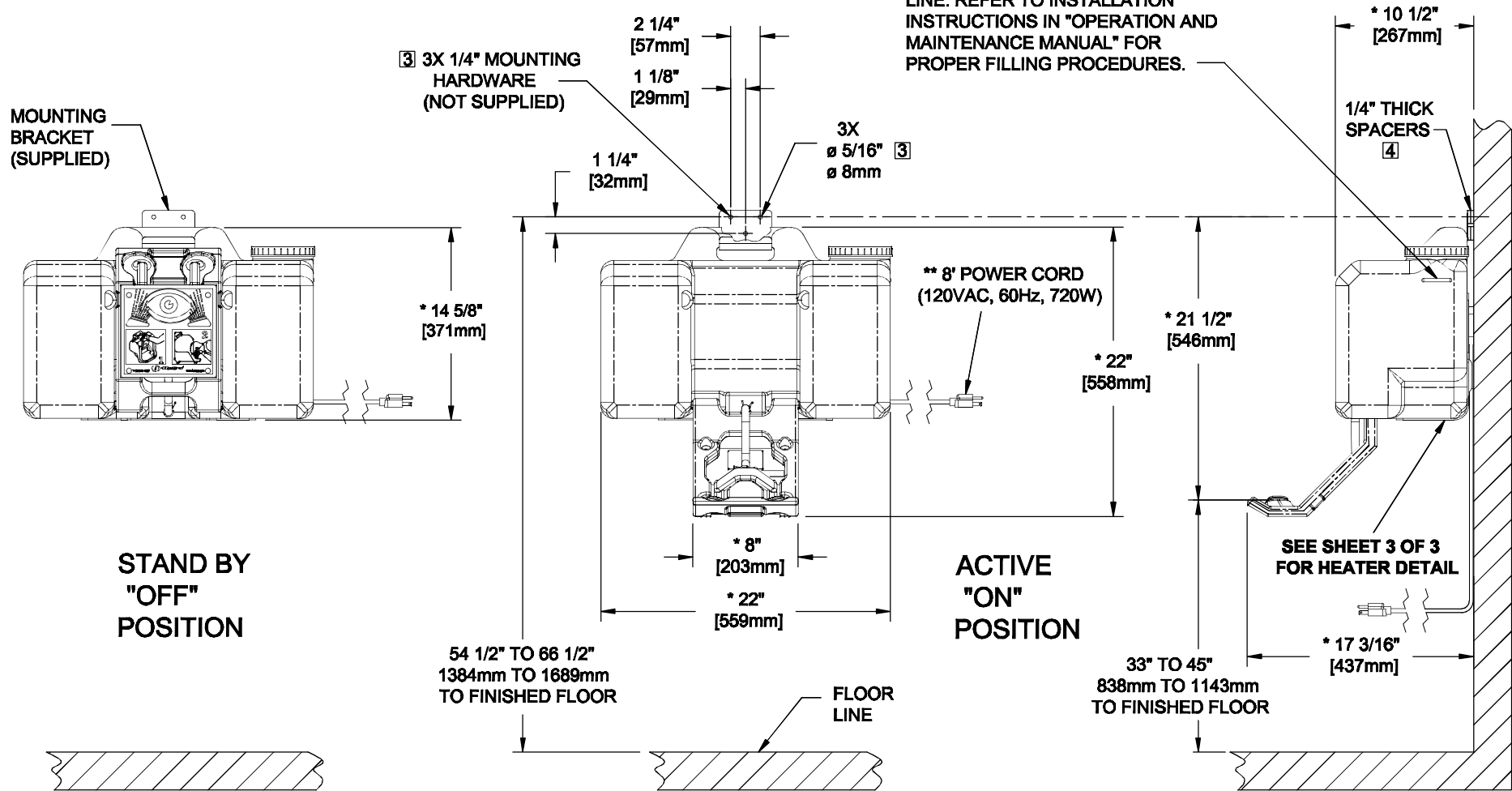

NOTES:

1. TO COMPLY WITH ANSI Z358.1-2009 FOR EMERGENCY EYEWASH OR EYE/FACE WASH AND SHOWER EQUIPMENT:
 - UNIT SHALL BE INSTALLED IN ACCORDANCE WITH MANUFACTURE'S INSTRUCTIONS AND ACCEPTABLE PLUMBING PRACTICES.
 - EYEWASH OR EYE/FACE WASH SHALL BE POSITIONED WITH NOZZLES NOT LESS THEN 83.3 CM (33 IN.) AND NO GREATER THAN 114.3 CM (45 IN.) FROM SURFACE ON WHICH USER STANDS AND 15.3 CM (6 IN.) MINIMUM FROM WALL OR NEAREST OBSTRUCTION.
2. UNIT MUST BE LEVEL FROM FRONT TO BACK AND SIDE TO SIDE.
3. ALL THREE MOUNTING HOLES ON MOUNTING-BRACKET MUST BE USED TO PROPERLY SECURE EYEWASH UNIT TO WALL.
4. LOCATE TWO 1/4" THICK SPACERS (QTY. 6 SUPPLIED) BEHIND EACH HOLE IN THE MOUNTING BRACKET AS SHOWN.
5. * DIMENSIONS MAY VARY \pm 1/2" [12.7mm].
6. ** UNIT MUST BE FILLED WITH WATER BEFORE CONNECTING TO POWER SOURCE. (NOTES CONTINUED ON SHEET 3 OF 3)

MODEL 7501FP - WITH HEATER (SHOWN)
MODEL 7501 (SEE SHEET 1 OF 3)

		1455 KLEPPE LANE SPARKS, NEVADA 89431 (775) 359-4712 FAX (755) 359-7424 E-MAIL: HAWS@HAWSCO.COM WEBSITE: WWW.HAWSCO.COM	
		ECN NO. REVISED PER BY: 4872 ECN: 4742 HM	MODEL(S) 7501 / 7501FP PORTABLE EYEWASH
DRAWN: P. FISCHER	DATE: 04/01/13	CHKD.: DATE:	DRAWING NO. 15153A00
APPROVED:	DATE:	SCALE: 1:12	DRAWING TYPE: INSTALLATION
		SIZE: A	SHEET 2 OF 3

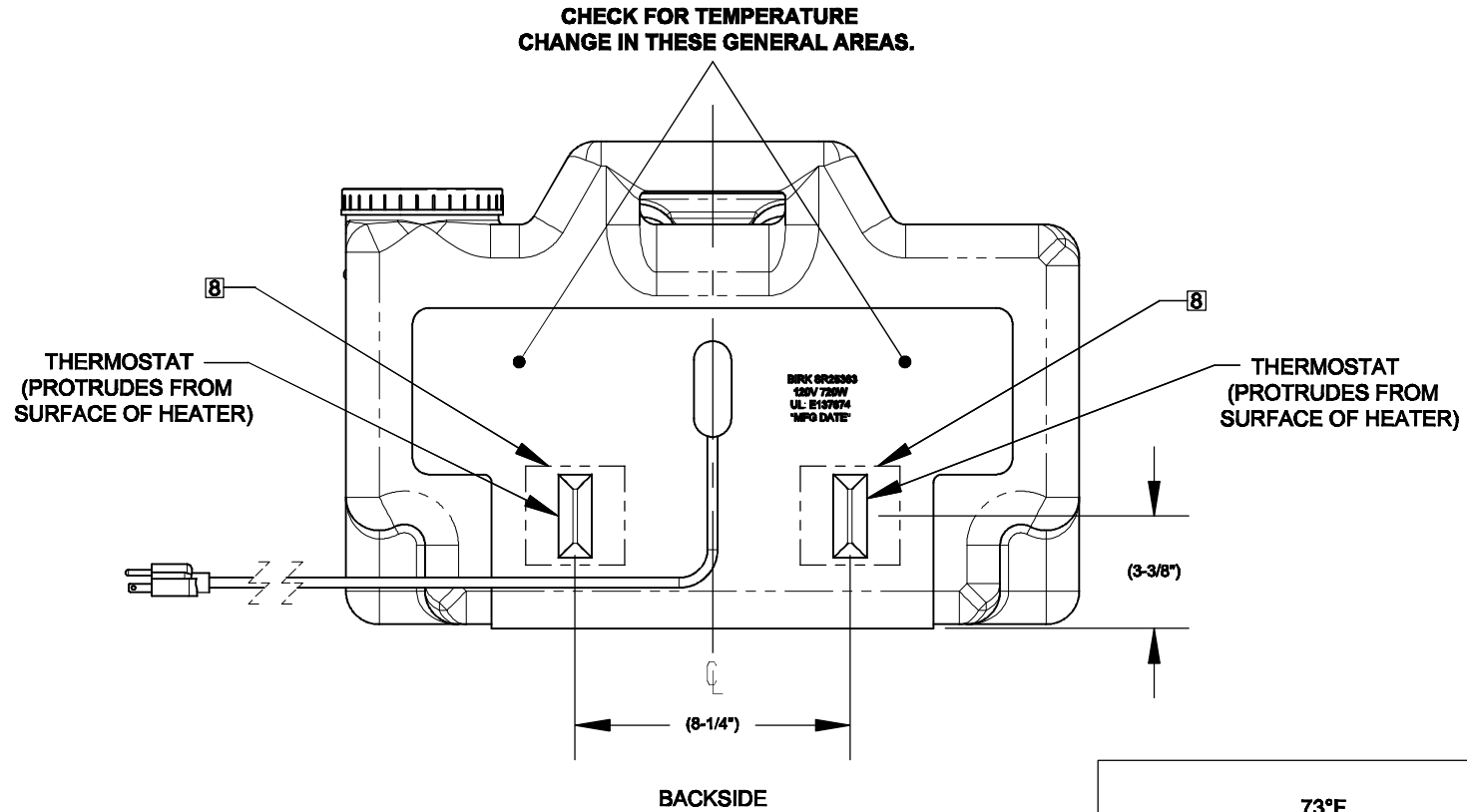

**MODEL 7501FP
HEATER DETAIL**

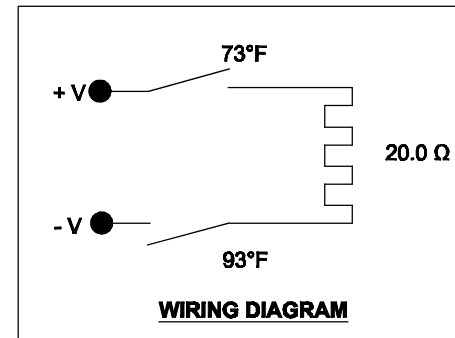

NOTES: (CONTINUED FROM SHEET 2 OF 3)

- 7. PRIOR TO SERVICING/CLEANING: UNPLUG POWER CORD ON UNIT FROM POWER SOURCE AND REMOVE UNIT FROM MOUNTING BRACKET.
- 8. EACH THERMOSTAT IS LOCATED IN THE CENTER OF A 3" X 3" NO HEAT ZONE. (SHOWN IN APPROXIMATE LOCATIONS). REFER TO OPERATIONS AND OWNERS MANUAL UNDER TROUBLESHOOTING "SECTION 7" (PAGE 4 OF 8) FOR HEATER ACTIVATION, ISSUES, AND TESTING.

		1455 KLEPPE LANE SPARKS, NEVADA 89431 (775) 358-4712 FAX (755) 358-7424 E-MAIL: HAWS@HAWSCO.COM WEBSITE: WWW.HAWSCO.COM	
		ECN NO. 4672 DRAWN: P. FISCHER APPROVED:	REVISED PER BY: HM ECN: 4742 DATE: 04/01/13 DATE:
SCALE: 1:12 DRAWING TYPE: INSTALLATION SIZE: A SHEET 3 OF 3			