

MINIMUM OF 1-1/4" (32mm) OF STUD MUST EXTEND OUT OF FINISHED WALL.

USE QTY 2 RUBBER SPACERS(QTY 8 SUPPLIED WITH BACK PANEL) ON EACH STUD (QTY 4 SUPPLIED) TO PROVIDE BACK PANEL SUPPORT.

MODEL	MTG HOLES	"X" DIM
1000	"G"	25-3/8" [645mm]
1001	"G"	25-3/8" [645mm]
1025	"D"	28-1/8" [714mm]
1047	"E"	27-1/2" [699mm]
1075	"E"	28" [711mm]
1105	"H"	34-5/16" [872mm]
1109	"H"	27-5/16" [694mm]
1116	"G"	25-3/8" [645mm]
1001FR	"G"	25-3/8" [645mm]
1109FR	"H"	27-5/16" [694mm]
1075FR	"E"	28" [711mm]
1311	"E"	26-3/4" [679mm]
1107L	"F"	26-3/16" [665mm]
1311TRIMCA	"E"	26-3/4" [679mm]

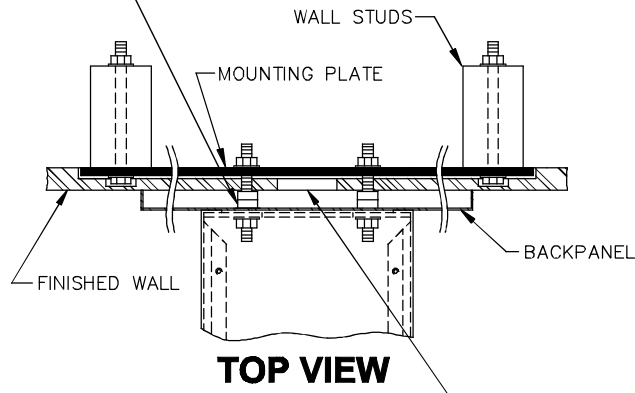
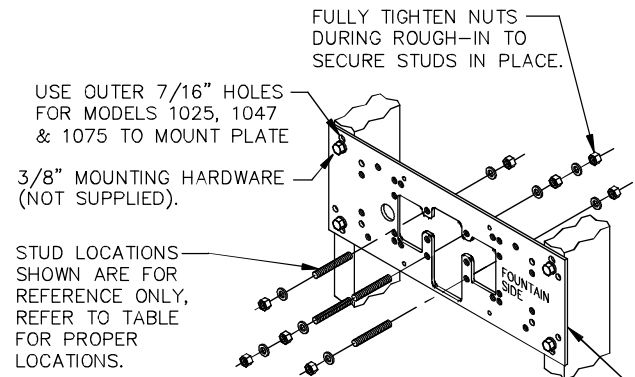

**CAUTION**

REGARDING CONCRETE/MASONRY WALL MOUNTING: DO NOT SECURE MOUNTING PLATE TO SAME SIDE OF WALL AS FOUNTAIN. AVOID COMPROMISING INTEGRITY OF WALL WHEN ANCHORING FOUNTAIN. IT IS RECOMMENDED THAT INSTALLER CALL TECHNICAL SUPPORT IF THERE ARE ANY QUESTIONS AS TO HOW TO OBTAIN A PROPER ANCHOR IN CONCRETE/MASONRY WALLS. 1-800-766-5612

1455 KLEPPE LANE  
SPARKS, NEVADA 89431  
(775) 359-4712 FAX (775) 359-7424  
E-MAIL: HAWS@HAWSCO.COM  
WEBSITE: WWW.HAWSCO.COM

ECN NO. REVISED PER BY:	ECN: 4913 VWC	MODEL(S)	PART NUMBER
DRAWN: C.JL	DATE: 09/03/03	<p>6700 MOUNTING PLATE, SINGLE</p>	0002080016
APPROVED:	DATE:		DRAWING NO. REV 05387C00 19
SCALE: 1/5		DRAWING TYPE: INSTALLATION	SIZE: A SHEET 1 OF 1