



model 5874PBF

Fountain valve

FEATURES & BENEFITS

DESIGN

With its patented push-button design which allows for front access stream adjustment as well as cartridge and strainer access, this valve offers the ultimate in ease of maintenance.

OPTIONS

- Valve Repair Kit: Model VRK5874, valve repair kit for Model 5874.

To see all options for this model, visit www.hawSCO.com



SPECIFICATIONS

Model 5874PBF fountain valve is a patented lead-free stainless steel push button valve shall include a polished chrome-plated brass flush mounted style push button assembly with front stream adjustment and cartridge serviceability, automatic pressure regulation from 30 - 90 psi (2.1 - 6.2 bar) and has a 1/4" IPS inlet and outlet.

APPLICATIONS

Specifically, this type of valve/button assembly is used as a replacement valve for many Haws fountains, whether it is to replace an existing 5874 valve or to change out the older style 5872 valve assembly. Haws manufactures drinking fountains and electric water coolers to be lead-free by all known definitions including NSF/ANSI Standard 61, Section 9, NSF/ANSI 372, California Proposition 65, and the Federal Safe Drinking Water Act.



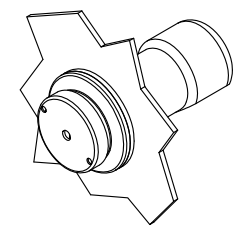
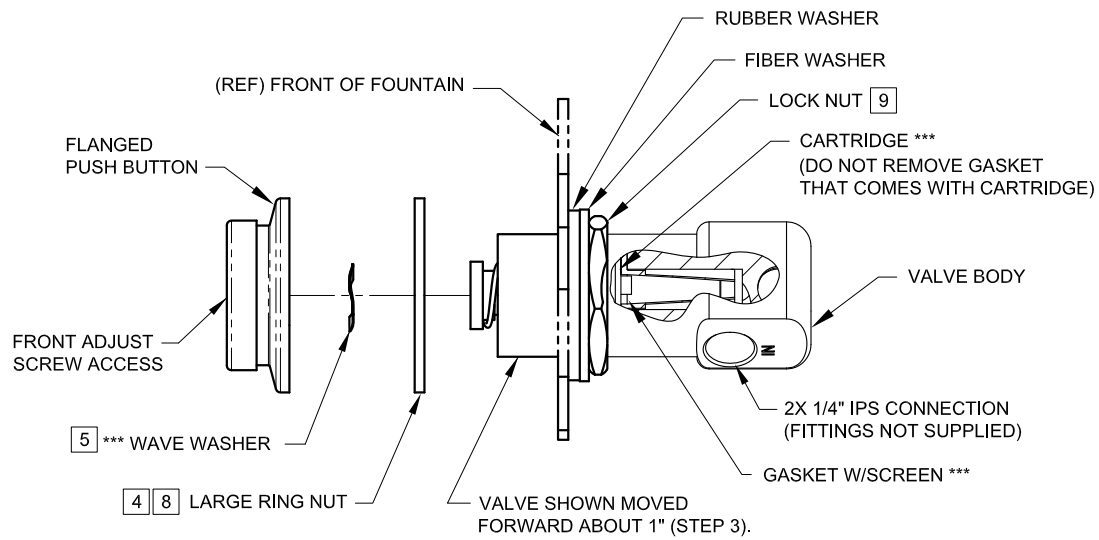

ASSEMBLED 5874PBF
(FLUSH MOUNT APPLICATION)

SEE SHEET 2 OF 2 FOR RECESSED MOUNT INSTRUCTIONS.

*** MODEL VRK5874 - VALVE REPAIR KIT (INCLUDES THESE ITEMS)
USED ON ALL 5874SS SERIES VALVES

INSTALLATION INSTRUCTIONS FOR 5874PBF OR 5874SS W/ PBA6

- 1) FOLLOW INSTRUCTIONS CAREFULLY ON O&M MANUAL (PAGE 2 OF 6) WHEN REMOVING OLD VALVE. **NOTE: SEE PARTS BREAKDOWN (PAGE 4 OF 6) FOR ADDITIONAL NOTES.**
- 2) VERIFY THAT LOCK NUT, FIBER, AND RUBBER WASHERS ARE POSITIONED SLIGHTLY PAST MIDWAY OF THREADS ON NEW VALVE BODY.
- 3) INSERT VALVE INTO FOUNTAIN FROM INSIDE AND PUSH FORWARD ABOUT 1".
- 4) THREAD LARGE RING NUT ONTO VALVE BODY, APPROXIMATELY 1" INTO VALVE.
- 5) PLACE WAVE WASHER INSIDE OF FLANGED PUSH BUTTON ASSEMBLY (**MUST BE IN PLACE**).
- 6) APPLY ONE (1) DOT OF LOCTITE 222MS, ON THE FEMALE THREADS OF BUTTON ASSEMBLY LEAVING THE FIRST AND LAST THREADS FREE. (FIGURE 1). **CAUTION: EXCESS LOCTITE CAN CAUSE THREADS TO LOCK VERY TIGHTLY, MAKING REPAIRS DIFFICULT.**
- **7) THREAD FLANGED PUSH BUTTON ASSEMBLY ON VALVE UNTIL WAVE WASHER MAKES SLIGHT CONTACT WITH STEM OF CARTRIDGE. **CAUTION: DO NOT HAND-TIGHTEN.**
- 8) UNTHREAD RING NUT FORWARD UNTIL IT STOPS FLUSH WITH PUSH BUTTON ASSEMBLY.
- 9) PUSH VALVE BACK TOWARD THE INSIDE OF FOUNTAIN AND TIGHTEN LOCKNUT (SEE ILLUSTRATION ABOVE).
- 10) TIGHTEN PUSH BUTTON ASSEMBLY USING UNIVERSAL SPANNER WRENCH PROVIDED.

** OVERTIGHTENING WILL PRE-ACTUATE VALVE AND CAUSE WEEPAGE, WHILE NOT ENOUGH CONTACT BETWEEN WAVE WASHER AND STEM CAN CAUSE A LOW FLOW CONDITION.

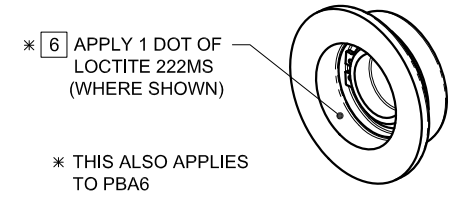

* 6) APPLY 1 DOT OF LOCTITE 222MS (WHERE SHOWN)

* THIS ALSO APPLIES TO PBA6

FIGURE 1

NOTE!
THIS VALVE IS PRESSURE COMPENSATING. BE SURE TO REMOVE ANY EXISTING FLOW CONTROL DEVICES. (MAY BE PRESENT IN FITTING OR SPUD).

		1455 KLEPPE LANE SPARKS, NEVADA 89431 (775) 359-4712 FAX (775) 359-7424 E-MAIL: HAWS@HAWS.CO.COM WEBSITE: WWW.HAWS.CO.COM	
		ECN NO. 4250 DRAWN: HLMERRITT APPROVED:	REVISED PER: ECN: 4553 DATE: 04/09/09 DATE:
SCALE: 1:1		DRAWING TYPE: INSTALLATION	SIZE: A SHEET 1 OF 2

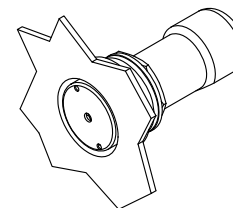
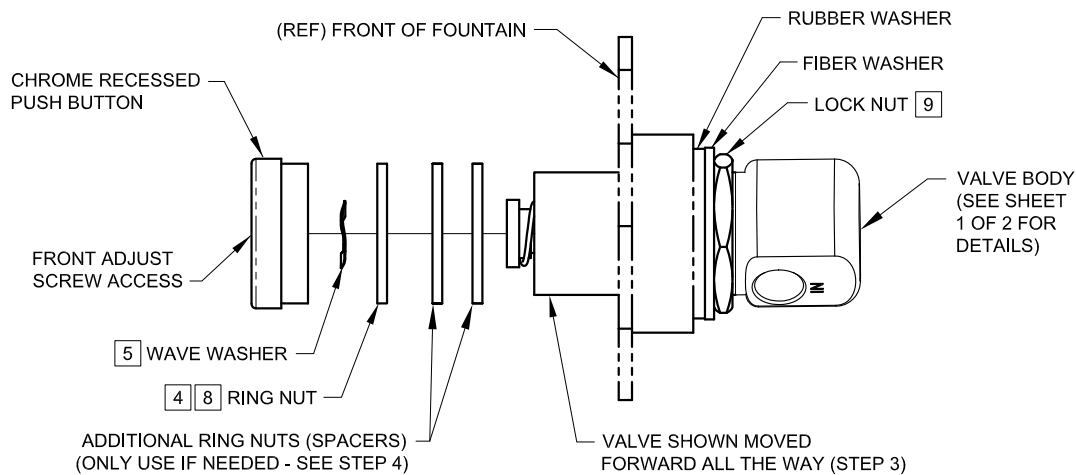

ASSEMBLED 5874PB
(RECESSED MOUNT APPLICATION)

SEE SHEET 1 OF 2 FOR FLUSH MOUNT INSTRUCTIONS.

INSTALLATION INSTRUCTIONS FOR 5874PB OR 5874SS W/ PBA7

- 1) FOLLOW INSTRUCTIONS CAREFULLY ON O&M MANUAL (PAGE 2 OF 6) WHEN REMOVING OLD VALVE. **NOTE: SEE PARTS BREAKDOWN (PAGE 4 OF 6) FOR ADDITIONAL NOTES.**
 - 2) VERIFY THAT LOCK NUT, FIBER, AND RUBBER WASHERS ARE POSITIONED TOWARD BOTTOM END OF THREADS ON NEW VALVE BODY.
 - 3) INSERT VALVE INTO FOUNTAIN FROM INSIDE, AND PUSH ALL THE WAY FORWARD (SEE ILLUSTRATION ABOVE).
 - 4) THREAD RING NUT ONTO VALVE BODY, AS FAR IN AS POSSIBLE, TOWARD FRONT OF FOUNTAIN. **NOTE: IF REPLACING A 5871 OR 5872 SERIES VALVE, YOU MAY HAVE TO PLACE ADDITIONAL RING NUTS (TO BE USED AS SPACERS AND SUPPLIED W/5874PB) IN FRONT OF THE RING NUT (SEE ILLUSTRATION ABOVE), TO ALLOW NEW LONGER VALVE TO FIT IN A TIGHT LOCATION.**
 - 5) PLACE WAVE WASHER INSIDE OF PUSH BUTTON ASSEMBLY (**MUST BE IN PLACE**).
 - 6) APPLY ONE (1) DOT OF LOCTITE 222MS, ON THE FEMALE THREADS OF BUTTON ASSEMBLY LEAVING THE FIRST AND LAST THREADS FREE. (FIGURE 1). **CAUTION: EXCESS LOCTITE CAN CAUSE THREADS TO LOCK VERY TIGHTLY, MAKING REPAIRS DIFFICULT.**
 - **7) THREAD PUSH BUTTON ASSEMBLY ON VALVE UNTIL WAVE WASHER MAKES SLIGHT CONTACT WITH STEM OF CARTRIDGE. **CAUTION: DO NOT HAND-TIGHTEN.**
 - 8) UNTHREAD RING NUT FORWARD UNTIL IT STOPS FLUSH WITH PUSH BUTTON ASSEMBLY.
 - 9) PUSH VALVE BACK TOWARD THE INSIDE OF FOUNTAIN AND TIGHTEN LOCKNUT (SEE ILLUSTRATION ABOVE).
 - 10) TIGHTEN PUSH BUTTON ASSEMBLY USING UNIVERSAL SPANNER WRENCH PROVIDED.
- ** OVERTIGHTENING WILL PRE-ACTUATE VALVE AND CAUSE WEEPAGE, WHILE NOT ENOUGH CONTACT BETWEEN WAVE WASHER AND STEM CAN CAUSE A LOW FLOW CONDITION.

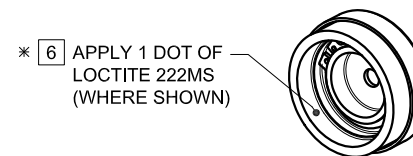

* 6) APPLY 1 DOT OF LOCTITE 222MS (WHERE SHOWN)

* THIS ALSO APPLIES TO PBA7

FIGURE 1

NOTE!

THIS VALVE IS PRESSURE COMPENSATING. BE SURE TO REMOVE ANY EXISTING FLOW CONTROL DEVICES. (MAY BE PRESENT IN FITTING OR SPUD).

		1455 KLEPPE LANE SPARKS, NEVADA 89431 (775) 359-4712 FAX (775) 359-7424 E-MAIL: HAWS@HAWS.CO.COM WEBSITE: WWW.HAWS.CO.COM	
		ECN NO. 4250 DRAWN: H. MERRITT APPROVED:	REVISED BY: VWC ECN: 4553 DATE: 04/09/09 DATE:
SCALE: 1:1		DRAWING TYPE: INSTALLATION	SIZE: A SHEET 2 OF 2