

FEATURES & BENEFITS

QUALITY CONTROL

Pre-built fountain pressure tested to ensure no leaks and proper functionality.

BUBBLER VALVE

Polished stainless steel cartridge valve which allows for top access stream adjustment as well as cartridge and strainer access, and is designed with a shielded, anti-squirt orifice that provides a steady sanitary source of water.

OPTIONS

- ❑ Water Filter: Model 6426, 12" x 2" (30.5 x 5.1 cm), in-line lead removal element that reduces lead from incoming water supply.

To see all options for this model, visit www.hawasco.com



SPECIFICATIONS

Model 4010 deck top sink shall include a Type 304 Stainless Steel, 20 gauge basin, polished stainless steel bubbler valve, cad plated steel mounting bracket with adjustable mounting bolts, and 1-1/4" O.D. tailpiece.

APPLICATIONS

Perfect for either public or private indoor settings, the 4010 is a great fit in areas where a countertop is the best fit for a drinking faucet/sink mount. Specifically, this type of deck mounted sink may be placed in settings such as: schools classrooms, laboratories, and other facilities where the need for a deck mounted sink/fountain is present. Dual purpose abilities allow the unit to provide multiple functions in one area and not take up excess space. Haws manufactures drinking fountains and electric water coolers to be lead-free by all known definitions including NSF/ANSI Standard 61, Section 9, NSF/ANSI 372, California Proposition 65, and the Federal Safe Drinking Water Act. Product is compliant to California Health and Safety Code 116875 (AB 1953-2006).

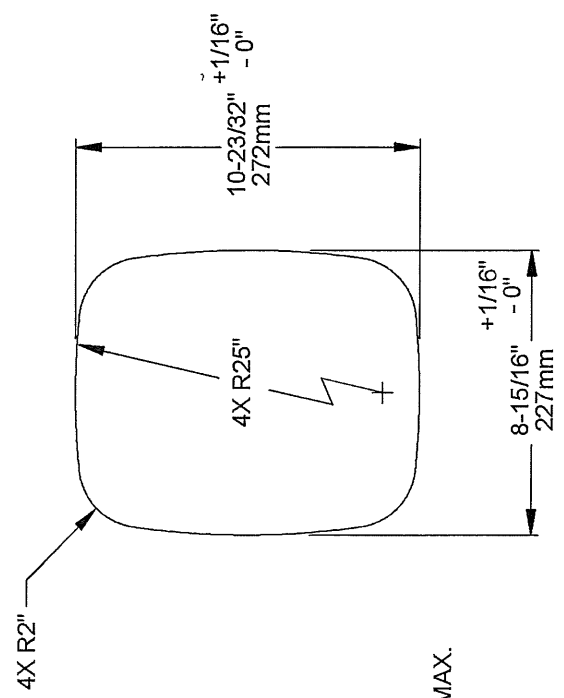
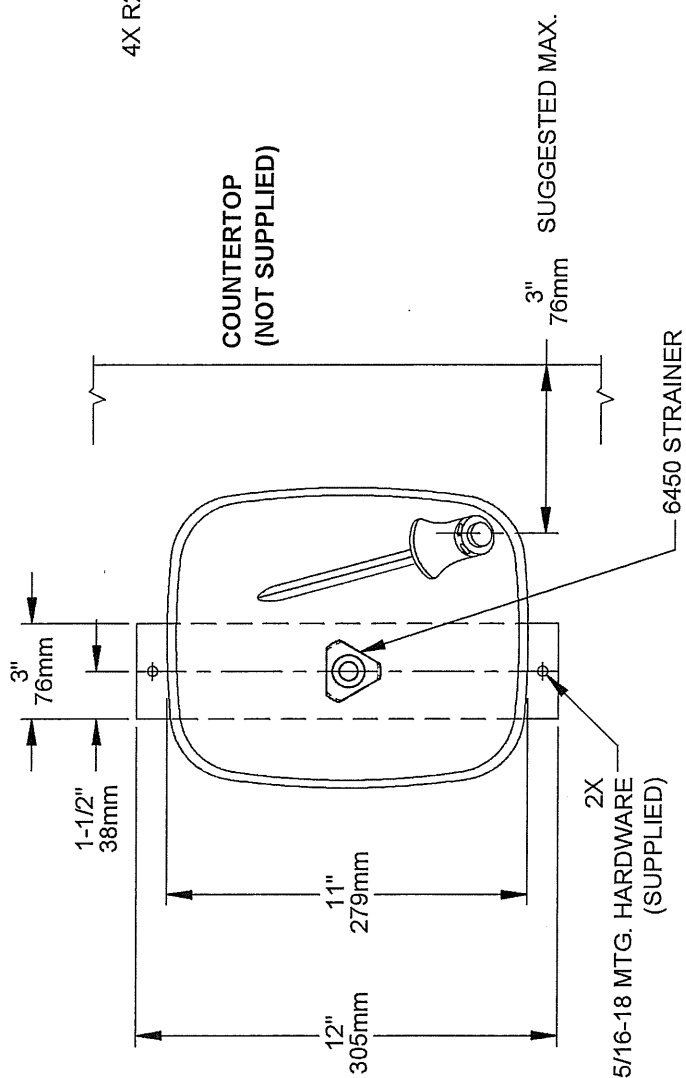
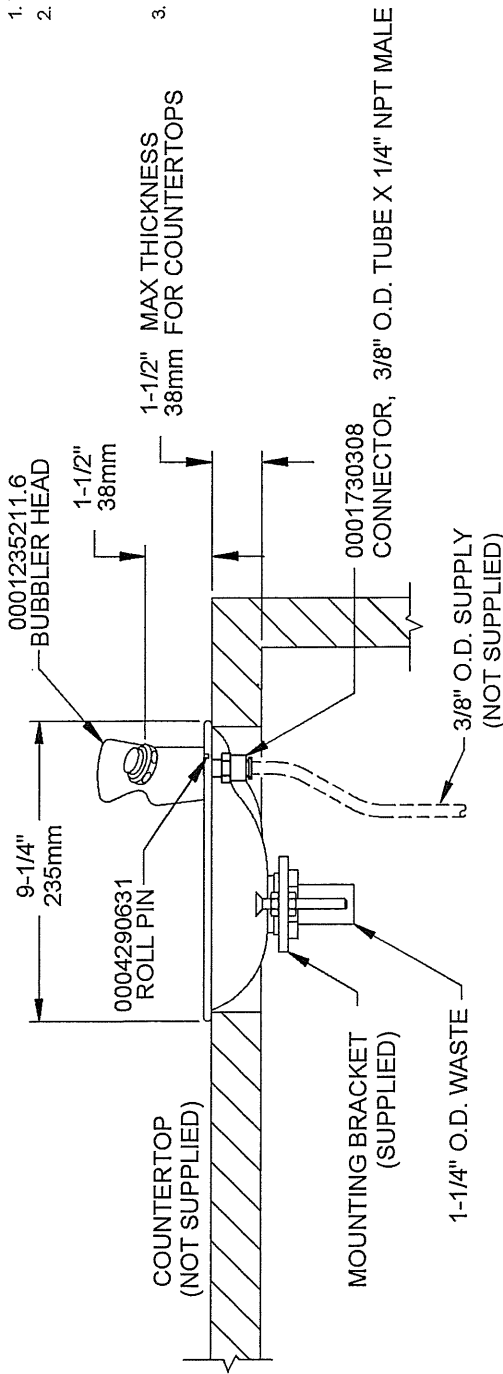

CUTOUT DETAIL

NOTES:

1. THESE DIMENSIONS MAY VARY ±1/4" (6.4mm)
2. FOR ALL PLASTIC PUSH-IN TYPE FITTING CONNECTIONS; PUSH TUBING INTO FITTING UNTIL IT BOTTOMS OUT TO ENSURE A WATERTIGHT CONNECTION. TO REMOVE, DEPRESS THE COLLET AND PULL TUBING OUT. ONLY CONNECT NSF-61 COPPER OR PLASTIC TUBING TO THESE PUSH-IN TYPE FITTINGS.
3. WHEN INSTALLING THIS UNIT, LOCAL, STATE, OR FEDERAL CODES SHOULD BE ADHERED TO FOR INSTALLATION DIMENSION (LOCATIONS), WASTE AND SUPPLY REQUIREMENTS OTHER THAN SHOWN.

1455 KLEPPE LANE
SPARKS, NEVADA 89431
(775) 359-4712 FAX (775) 359-7424
E-MAIL: HAWS@HAWS.CO.COM
WEBSITE: WWW.HAWS.CO.COM

ECN NO. REVISED PER BY:	MODEL(S)
ECN: 4754	4010
DRAWING NO.:	DRINKING FOUNTAIN
APPROVED DATE:	SCALE: 1:8 DRAWING TYPE: INSTALLATION
PART NUMBER:	SIZE: A SHEET 1 OF 1
0002077460	
DRAWING NO.:	REV.
00159C00	9