



model **3482**  
Pedestal Fountain

## FEATURES & BENEFITS

### CONSTRUCTION

Stainless steel basin with a high-polished finish compliments almost any setting, and it also resists stains and corrosion.

### QUALITY CONTROL

Pre-built fountain pressure tested to ensure no leaks and proper functionality.

## OPTIONS

To see all options for this model, visit [www.hawesco.com](http://www.hawesco.com)



## SPECIFICATIONS

Model 3482 pedestal drinking fountain shall include a polished stainless steel basin, polished chrome-plated brass bubbler head, polished chrome-plated brass lever valve with adjustable stream regulation, galvanized steel stanchion, 9" (22.9 cm) powder-coated steel floor flange, and 1/2" IPS inlet.

## APPLICATIONS

Perfect for either public or private settings, the 3482 pipe pedestal drinking fountain is great for those looking to obtain a full functioning fountain with a simplistic design. Unit fits nicely into campground settings and other environments that are in more remote areas where drinking fountain facilities are still needed. Corrosion resistant stainless steel bowl and lever handle valve with adjustable stream makes for just the right combination of protection and adjustability needed in a basic outdoor fountain. Haws manufactures drinking fountains and electric water coolers to be lead-free by all known definitions including NSF/ANSI Standard 61, Section 9, NSF/ANSI 372, California Proposition 65, and the Federal Safe Drinking Water Act. Product is compliant to California Health and Safety Code 116875 (AB 1953-2006).



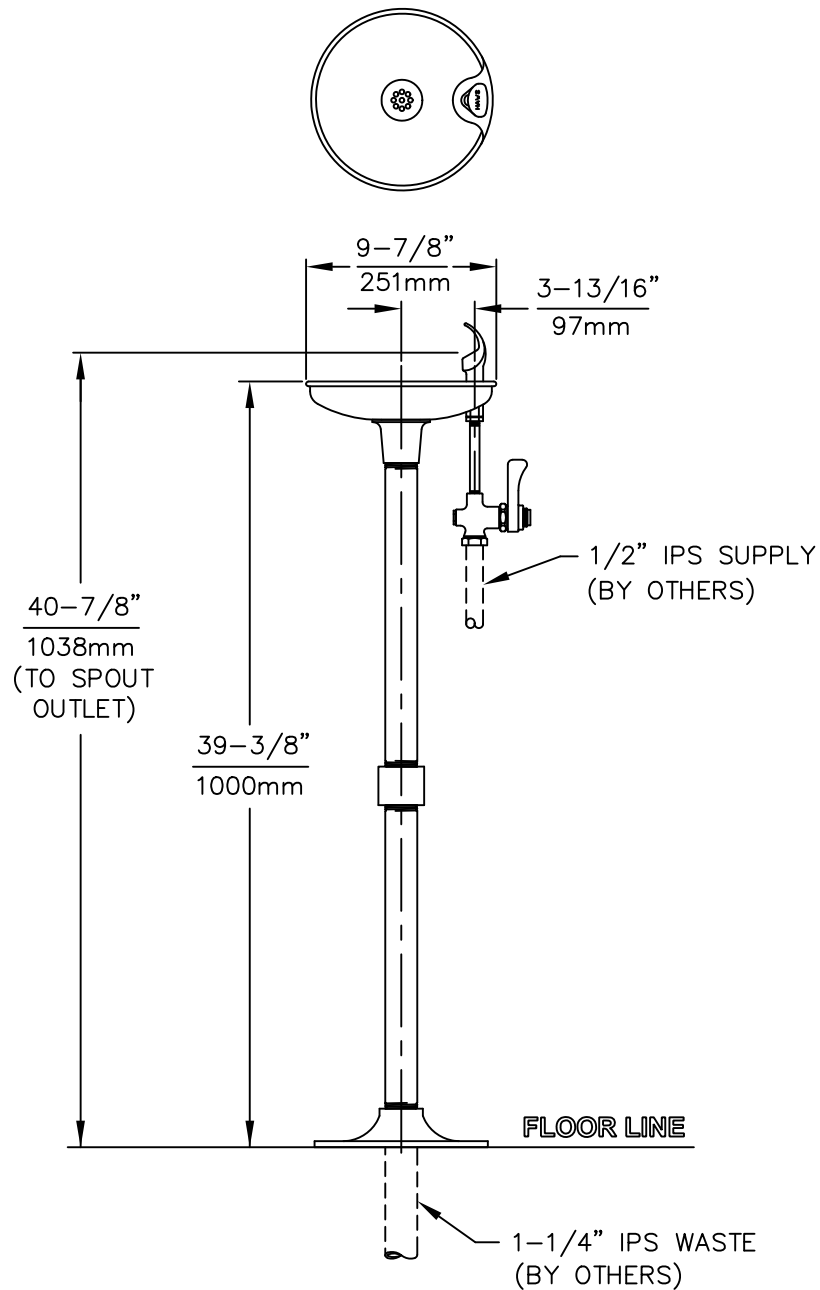

TO ADJUST FLOW, TURN ADJUSTMENT SCREW  
COUNTER CLOCKWISE TO INCREASE FLOW, AND  
CLOCKWISE TO DECREASE FLOW.

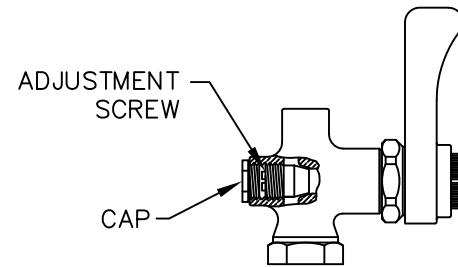

**VALVE DETAIL**  
SCALE: 3X

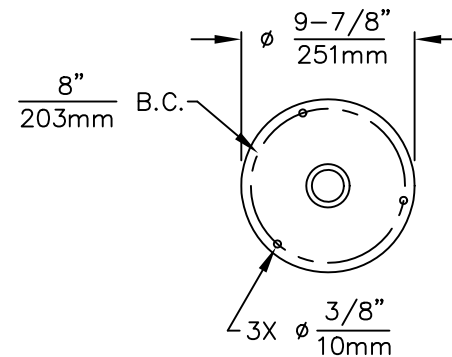

**MOUNTING DETAIL**

ROUGH-IN DIMENSIONS MAY VARY  $\pm 1/4"$  (6.4mm).

		INFO FAX : 1-888-FAX-HAWS (1-888-329-4297) 1455 Kleppe Ln, Sparks NV, 89431 Phone: 775-359-4712 Fax: 775-359-7424 Haws Ag Bachweg 3 CH-3401 Burgdorf Switzerland Haws Mfg Pte Ltd 74 Sungei Kadut Loop Singapore 729531 e-mail: Haws@hawsco.com website: www.hawsco.com	
		ECR NO. REVISED PER BY: ECN: 387B HM DRAWN: DATE: 06/92 CHK'D: C.I.L. DATE: INFO FAX DOC #: 23482 APPROVED: DATE: SCALE: 1:10 DRAWING TYPE: INSTALLATION/FAXBACK	MODEL(S): 3482 PART NUMBER: 002077446.D DRAWING NUMBER: 10210C00 REV: 11 SIZE: A   SHT: 1 OF 1

DWG. NO. 10210C00