

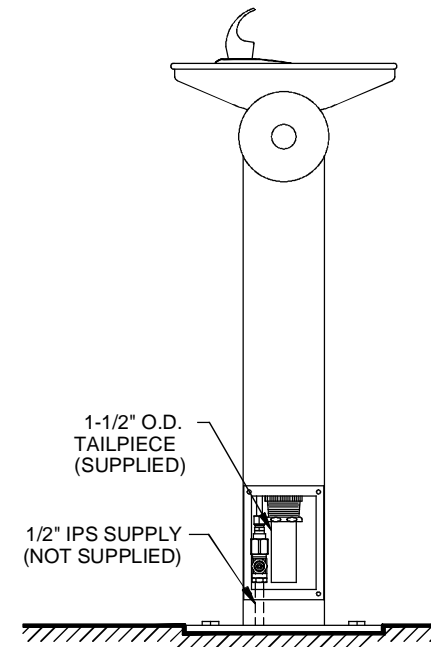

THIS DOCUMENT IS TRUE AND CORRECT AT TIME OF PUBLICATION. CONTINUED PRODUCT IMPROVEMENTS MAKE SPECIFICATIONS AND MEASUREMENTS SUBJECT TO CHANGE WITHOUT NOTICE.

**NOTES:**

- REFER TO 5874SS OPERATION AND MAINTENANCE MANUAL FOR PUSH BUTTON AND VALVE INSTALLATION/ MAINTENANCE INSTRUCTIONS.

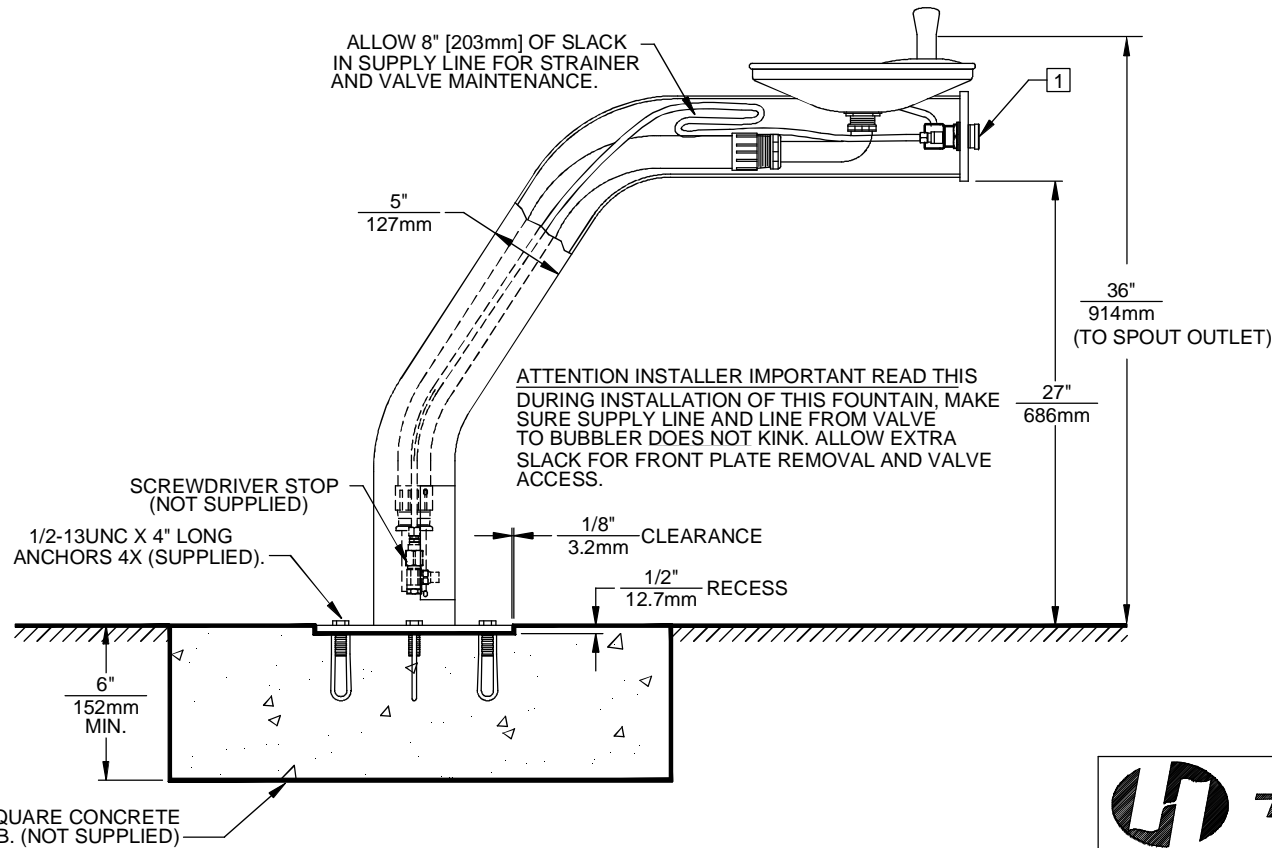
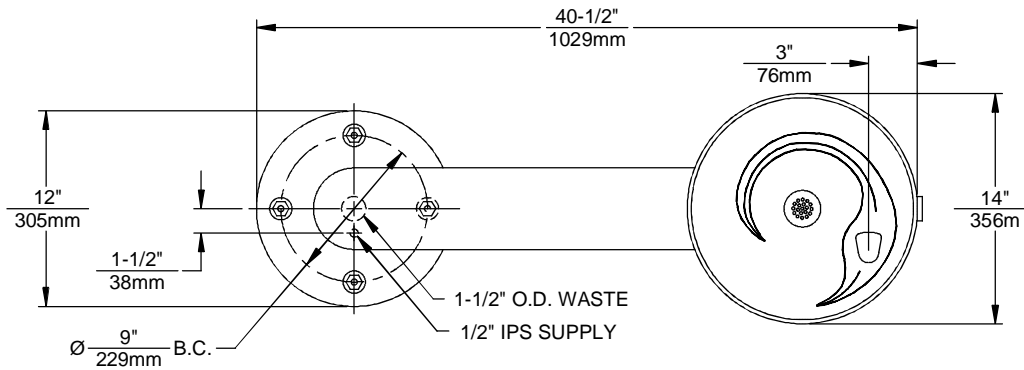

 <b>Haws</b> <sup>®</sup>		1455 KLEPPE LANE SPARKS, NEVADA 89431 (775) 359-4712 FAX (755) 359-7424 E-MAIL: HAWS@HAWSCO.COM WEBSITE: WWW.HAWSCO.COM	
		ECN NO. REVISED PER BY: ECN: 4928   HM	MODEL(S) 3380/3380G
DRAWN: C. HAYES	DATE: 07/27/92	CHKD.:	DRAWING NO. 10253A00
APPROVED:	DATE:	SCALE: 1:12   DRAWING TYPE: INSTALLATION	SIZE: A   SHEET 1 OF 1