



model 3202G

Barrier-Free Steel Pedestal Fountain

FEATURES & BENEFITS

CONSTRUCTION

Heavy-duty 12 gauge rough unfinished galvanized surface steel finish that incorporates a recessed push button and welded bubbler guard to provide extra durability, a large access panel for ease of service, and a vandal-resistant bottom plate for added peace of mind.

BARRIER-FREE

Barrier-free capabilities combined with its ease of use allows for a number of installation location possibilities.

DRAIN FREE

Unique design allows this pedestal fountain to be placed in the harshest of outdoor environments without the worry of a clogged drain. When water is activated, the excess flow runs from its trough basin off the back and onto the ground - perfect for beaches, play grounds, and other areas high in debris.

BUBBLER HEAD

Polished chrome-plated brass bubbler head with integral basin shank for added strength. Shielded, angled stream opening provides a steady, sanitary source of drinking water.

PUSH BUTTON VALVE

The push-button activated valve assembly allows for front access stream adjustment as well as cartridge and strainer access. The valve works at an operating pressure range of 30 to 90 psi (2.1 to 6.2 bar).

OPTIONS

- Faucet Valve: Model 6250LF, self-closing, plain end, lead-free, brass bib faucet with polished chrome-plated finish. (When used with Haws concrete products, also order part 0004499489; for 3511, use 0004521763)

To see all options for this model, visit www.hawesco.com



SPECIFICATIONS

Model 3202G barrier-free pedestal drinking fountain shall include a 12 gauge rough unfinished galvanized surface steel pedestal, push-button operated stainless steel valve with front-accessible cartridge and flow adjustment, 100% lead-free waterways, polished chrome-plated brass vandal-resistant bubbler head backed against a pedestal guard, trough design in the pedestal instead of a waste to eliminate clogging and a 1/4" (.6 cm) spacer to raise the pedestal off the ground which reduces the potential for corrosion, integral mounting feet, and an over-size vandal-resistant access plate.

APPLICATIONS

Perfect for either public or private settings, the 3202G trough style fountain is a great fit in areas more prone to drain clogging. Completely eliminating the need for a traditional fountain drain, trough fountains are a nice complement to outdoor environments where a gravel fill can be implemented. Heavy-duty steel and galvanized finish make for a solid freestanding design that will hold up and blend in with the environment. More specifically, this fountain is applicable in forest/campground environments as well as parks, schools, and other outdoor areas where drinking facilities are needed. Model meets all current Federal Regulations for the disabled including those in the Americans with Disabilities Act. Haws manufactures drinking fountains and electric water coolers to be lead-free by all known definitions including NSF/ANSI Standard 61, Section 9, NSF/ANSI 372, California Proposition 65, and the Federal Safe Drinking Water Act. Product is compliant to California Health and Safety Code 116875 (AB 1953-2006).



THIS DOCUMENT IS TRUE AND CORRECT AT TIME OF PUBLICATION. CONTINUED PRODUCT IMPROVEMENTS MAKE SPECIFICATIONS AND MEASUREMENTS SUBJECT TO CHANGE WITHOUT NOTICE.

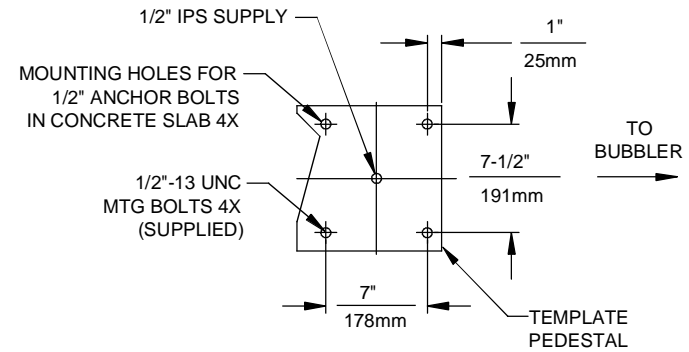
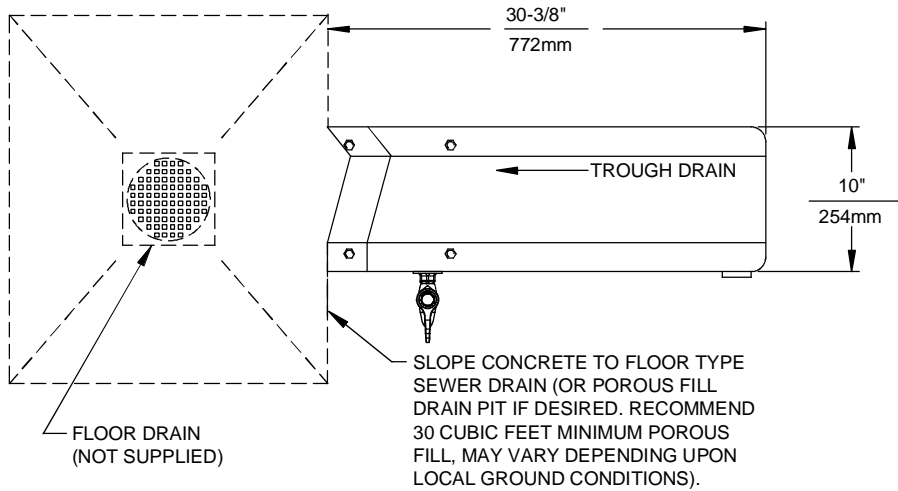

MOUNTING DETAIL

IMPORTANT: ATTENTION INSTALLER

USE CARE TO AVOID KINKS WHEN ROUTING SUPPLY LINE TO VALVE AND FROM VALVE TO BUBBLER

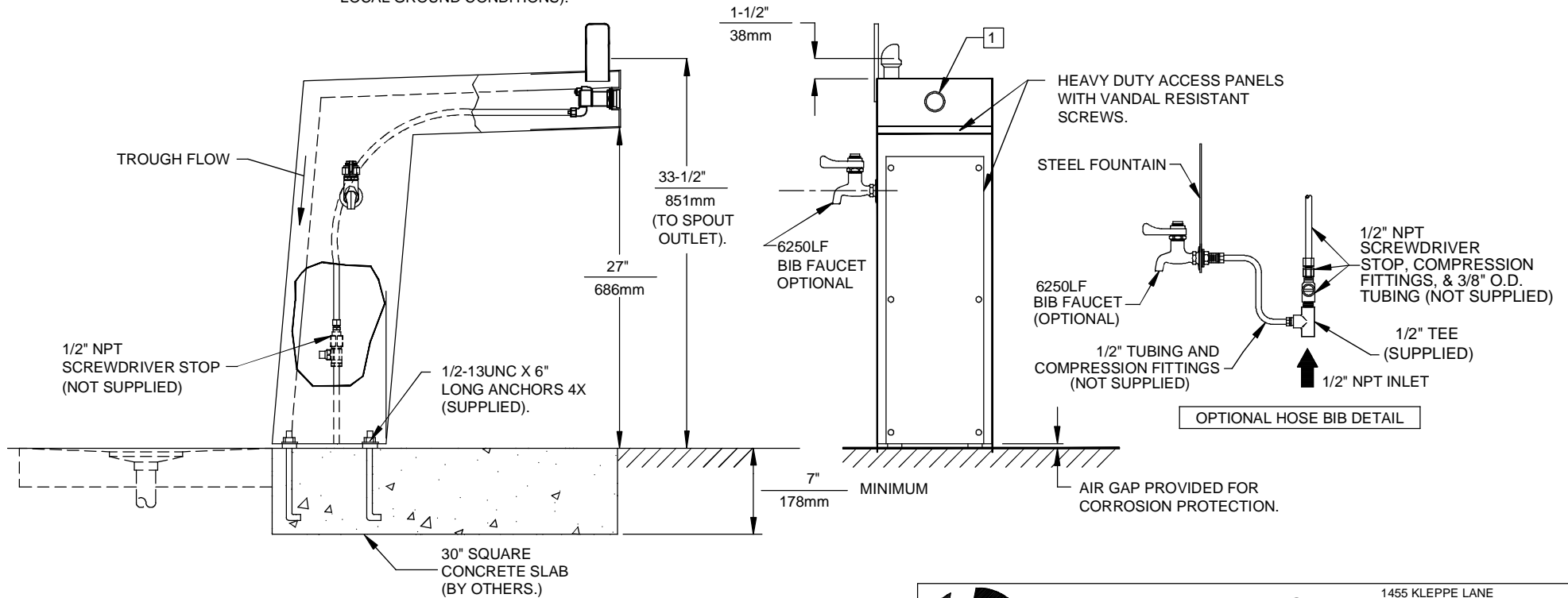

NOTES:

- 1 REFER TO 5874SS OPERATION AND MAINTENANCE MANUAL FOR PUSH BUTTON AND VALVE INSTALLATION/MAINTENANCE INSTRUCTIONS.



Haws

1455 KLEPPE LANE
SPARKS, NEVADA 89431
(775) 359-4712 FAX (775) 359-7424
E-MAIL: HAWS@HAWS.CO.COM
WEBSITE: WWW.HAWS.CO.COM

ECN NO. REVISED PER BY:		MODEL(S)		PART NUMBER	
ECN: 4828		HM		0002077328.D	
DRAWN:	DATE:	CHKD.:	3202/3202G		DRAWING NO. REV
C. HAYES	11/91				09912A00 23
APPROVED:	DATE:	SCALE: 1:14		DRAWING TYPE: INSTALLATION	SIZE: A SHEET 1 OF 1