



model 3177FR

Barrier-Free Freeze Resistant Concrete Pedestal Fountain

FEATURES & BENEFITS

PUSH BUTTON

Polished chrome-plated push-button requires less than 5 lbs. (2.7 kg) of push force to activate.

CONSTRUCTION

Heavy-duty wire reinforced concrete construction with exposed aggregate finish provide a perfect addition to outside environments, along with vandal-resistant bottom and access plates for added peace of mind. Stainless steel basin with a high-polished finish compliments almost any setting, and it also resists stains and corrosion.

DRAIN CLEAN-OUT

Top-down access to the drain allows the fountain to be cleaned without taking the unit apart, good for outdoor settings with drain-clogging sediment such as leaves, garbage, and other debris.

FREEZE-RESISTANT VALVE

Fully engineered system with the pneumatic operated freeze-resistant valve installed below frost line to drain water to non-freezing depth allowing fountain to function year-round. Assembly can be lifted to surface and lowered back into casing for easy maintenance without disturbing the fountain.

BUBBLER HEAD

Polished chrome-plated brass bubbler head with integral basin shank for added strength. Shielded, angled stream opening provides a steady, sanitary source of drinking water.



SPECIFICATIONS

Model 3177FR barrier-free, freeze-resistant concrete pedestal drinking fountain shall include a polished stainless steel basin, polished chrome-plated brass push-button, polished chrome-plated brass vandal-resistant bubbler head protected by a hood extension, polished chrome-plated vandal-resistant waste strainer with top-down clean-out access, Portland Gray exposed aggregate concrete finish with wire reinforcement, integral mounting plate, vandal-resistant stainless steel access plates, and 1-1/2" O.D. tailpiece. REQUIRES MODEL 6518FR PRICED SEPARATELY.

OPTIONS

To see all options for this model, visit www.hawsc.com

APPLICATIONS

Perfect for either public or private settings, our concrete series is a great fit in "open-air" environments. Suitable in areas where weather conditions may be cause for concern, this series stands strong against any elements. Wire reinforced concrete cast design not only protects from corrosion, its Portland Gray color makes it recognizable enough to locate without compromising the outdoor atmosphere. This type of pedestal drinking fountain may also be placed in a variety of settings such as: parks, schools, and other recreational outdoor environments where the temperature may drop into freezing conditions. Model meets all current Federal Regulations for the disabled including those in the Americans with Disabilities Act. Haws manufactures drinking fountains and electric water coolers to be lead-free by all known definitions including NSF/ANSI Standard 61, Section 9, NSF/ANSI 372, California Proposition 65, and the Federal Safe Drinking Water Act. Product is compliant to California Health and Safety Code 116875 (AB 1953-2006).



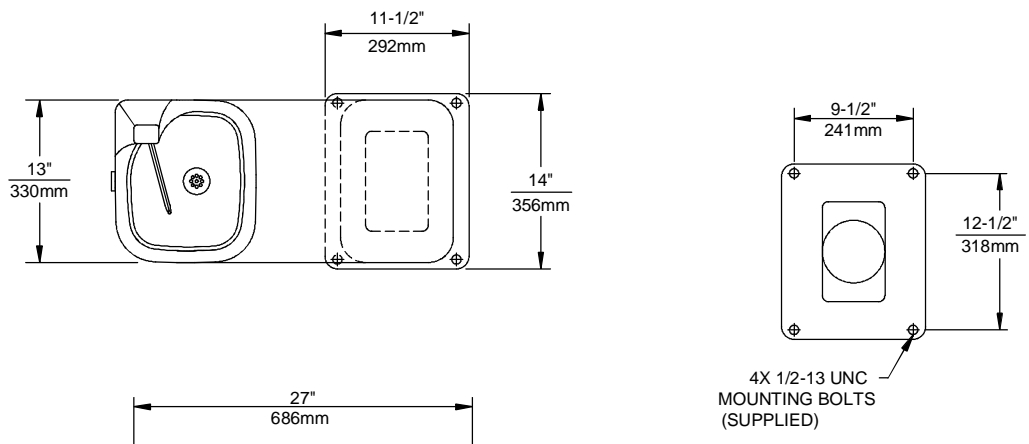

MOUNTING DETAIL

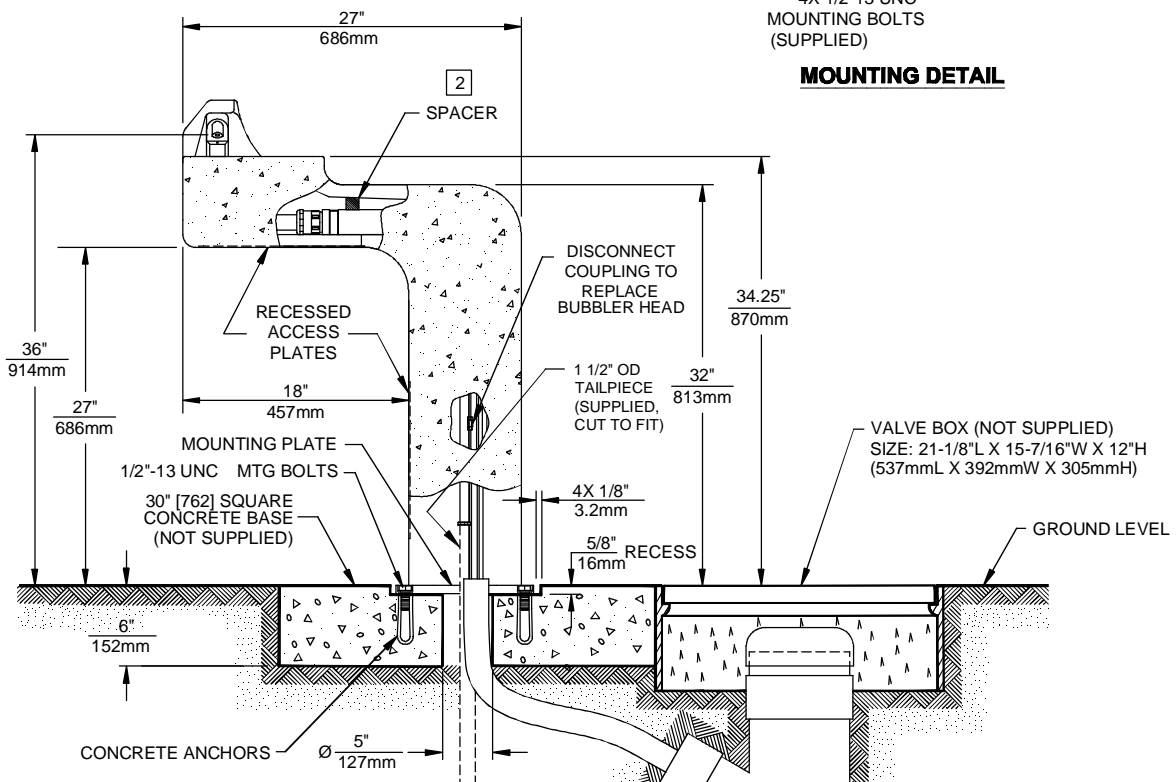

BURY DEPTHS OF 48" [1219mm] AND 72" [1829mm]. WASTE TO BE 1 1/2" IPS MINIMUM TO A POROUS GRAVEL FILL OR MAIN SEWER LINE LOCATED BELOW FROST LINE (NOT SUPPLIED).

NOTES:

1. -REMOVED-
2. SPACER IS GLUED TO WALL OF PEDESTAL, BUT MAY BE KNOCKED OFF DURING WASTE ARM ASSEMBLY REMOVAL/REPAIR. ENSURE THAT SPACER IS REPLACED TO KEEP HOSE AND WASTE ARM ALIGNED PROPERLY.

6518FR VALVE ASSY



1455 KLEPPE LANE
 SPARKS, NEVADA 89431
 (775) 359-4712 FAX (775) 359-7424
 E-MAIL: HAWS@HAWSCO.COM
 WEBSITE: WWW.HAWSCO.COM

CON. NO.	REVISED PER:	DATE	CHK'D.	SCALE	DRAWING TYPE	SIZE	SHEET
DRAWN:	HM	12/01/95	VWC	1:1	INSTALLATION	A	1 OF 1
APPROVED:	FV	04/21/15					
MODEL(S)	3177FR						
PART NUMBER	0002077325.D						
REVISION	10						