



# INSTALLATION, OPERATION & MAINTENANCE INSTRUCTIONS

1455 Kleppe Lane ♦ Sparks, NV 89431-6467 ♦ (775) 359-4712 ♦ Fax (775) 359-7424  
E-mail: [haws@hawsco.com](mailto:haws@hawsco.com) ♦ website: [www.hawsco.com](http://www.hawsco.com)

No.2077064 (11)

## Model 3121FR Drinking Fountain

**NOTE TO INSTALLER:** Please leave this information with the Maintenance Department.

### LIMITED WARRANTY

HAWS warrants that this specific product is guaranteed against defective material or poor workmanship for a period of **one year from date of shipment**. HAWS liability under this warranty shall be discharged by furnishing without charge F.O.B. HAWS Factory any goods, or part thereof, which shall appear to the Company upon inspection to be of defective material or not of first class workmanship, provided that claim is made in writing to Haws within a reasonable period after receipt of the product. Where claims for defects are made, the defective part or parts shall be delivered to the Company, prepaid, for inspection. HAWS will not be liable for the cost of repairs, alterations or replacements, or for any expense connected therewith made by the owner or his agents, except upon written authority from HAWS, Sparks, Nevada. HAWS will not be liable for any damages caused by defective materials or poor workmanship, except for replacements, as provided above. Buyer agrees that HAWS shall not be liable for general, special, or consequential damages claimed to arise under the contract of sale. The drinking fountain manufactured by HAWS is warranted to function if installation and maintenance instructions provided are adhered to. The units also must be used for the purpose for which they were intended.

**NO OTHER WARRANTIES EXPRESSED OR IMPLIED ARE AUTHORIZED,  
PROVIDED OR GIVEN BY HAWS.**

**SHOULD YOU EXPERIENCE DIFFICULTY WITH THE INSTALLATION OF THIS  
MODEL PLEASE CALL:**

**TECHNICAL SUPPORT: 1-800-766-5612**

**FOR CUSTOMER SERVICE: 1-888-640-4297**

**RECOMMENDED TOOLS:** Hack saw, pipe joint sealant, screwdriver, level, 12" adjustable wrench, 10" pipe wrench, 5/64" hex key wrench, 9/16", 1/2", 7/16" socket wrench or open end wrench.

**LOCATION OF UNIT:** When installing Model 3121FR Drinking Fountain, local, state or federal codes should be adhered to. If height other than shown is required, then dimensions must be adjusted accordingly.

**SUPPLY LINE:** The minimum recommended line size is 1/2"IPS. Flowing pressure is 30-90 psi (2-6 ATM) for Model 3121FR. Where sediment or mineral content is a problem, an inlet filter is recommended.

**PLUMBING CONNECTIONS:** Waste outlet is 1-1/4" IPS.

**MAINTENANCE:** Periodically clean the strainer. Refer to 6518FR Operation and Maintenance Sheet for additional information.

### TROUBLESHOOTING 3121FR

PROBLEM	REPAIR CHECKLIST
1. Insufficient bubbler flow.	1a. Check that inlet screwdriver stop valve is wide open. (Customer supplied). Turn counterclockwise. b. Verify minimum 30psi flowing supply pressure. c. Adjust valve to increase flow. See 6518FR Valve Manual.

**General Notes:**

Before tightening nut and ferrule assembly, push tubing into fitting until it bottoms out to ensure correct engagement with O-Ring.

For more information about Haws products, see our website: [www.hawesco.com](http://www.hawesco.com)

# PARTS BREAKDOWN

ITEM	DESCRIPTION	PART NO.
1	VALVE	6518FR
2	STRAINER ASSY	6466
3	BUBBLER HEAD	5703M
4	PUSH BTN ASS'Y	5881PBA
5	DRIVER, NOZZLE .25 HEX	0002082253

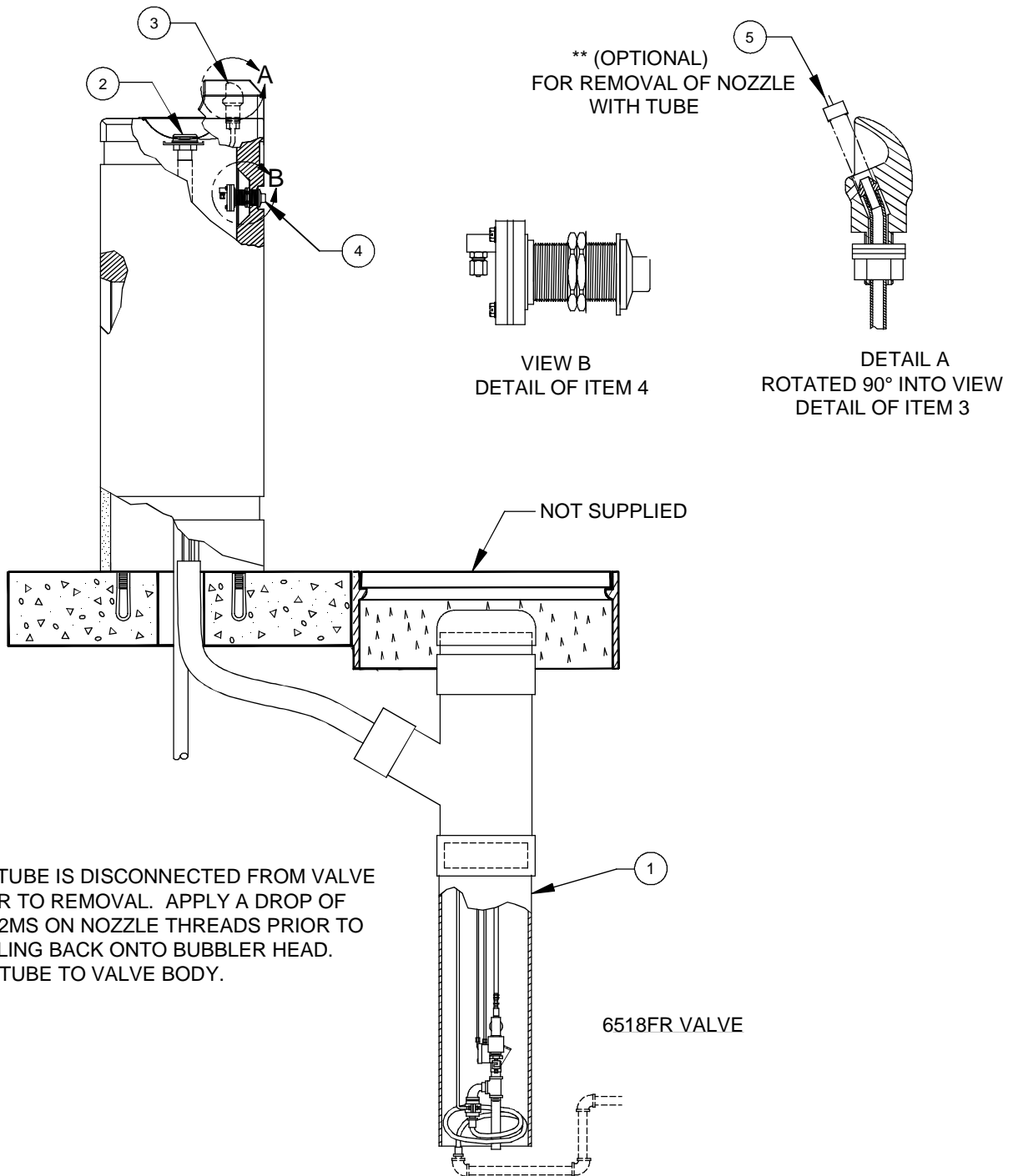

**\*\* ENSURE TUBE IS DISCONNECTED FROM VALVE BODY PRIOR TO REMOVAL. APPLY A DROP OF LOCTITE 222MS ON NOZZLE THREADS PRIOR TO REASSEMBLING BACK ONTO BUBBLER HEAD. REATTACH TUBE TO VALVE BODY.**

6518FR VALVE

		1455 KLEPPE LANE SPARKS, NEVADA 89431 (775) 359-4712 FAX (775) 359-7424 E-MAIL: HAWS@HAWS.CO.COM WEBSITE: WWW.HAWS.CO.COM	
		ECN NO. REVISED PER BY ECN: 4535 HM	MODEL(S) 3121FR
DRAWN D. OLLOM	DATE 11/25/95	CHKD VWC	REVISION 11
APPROVED FV	DATE 04/21/15	SCALE: 1:1	DRAWING TYPE: PARTS BREAKDOWN
WHEN ORDERING PARTS PLEASE SPECIFY MODEL NUMBER.		SIZE: A	SHEET 1 OF 1

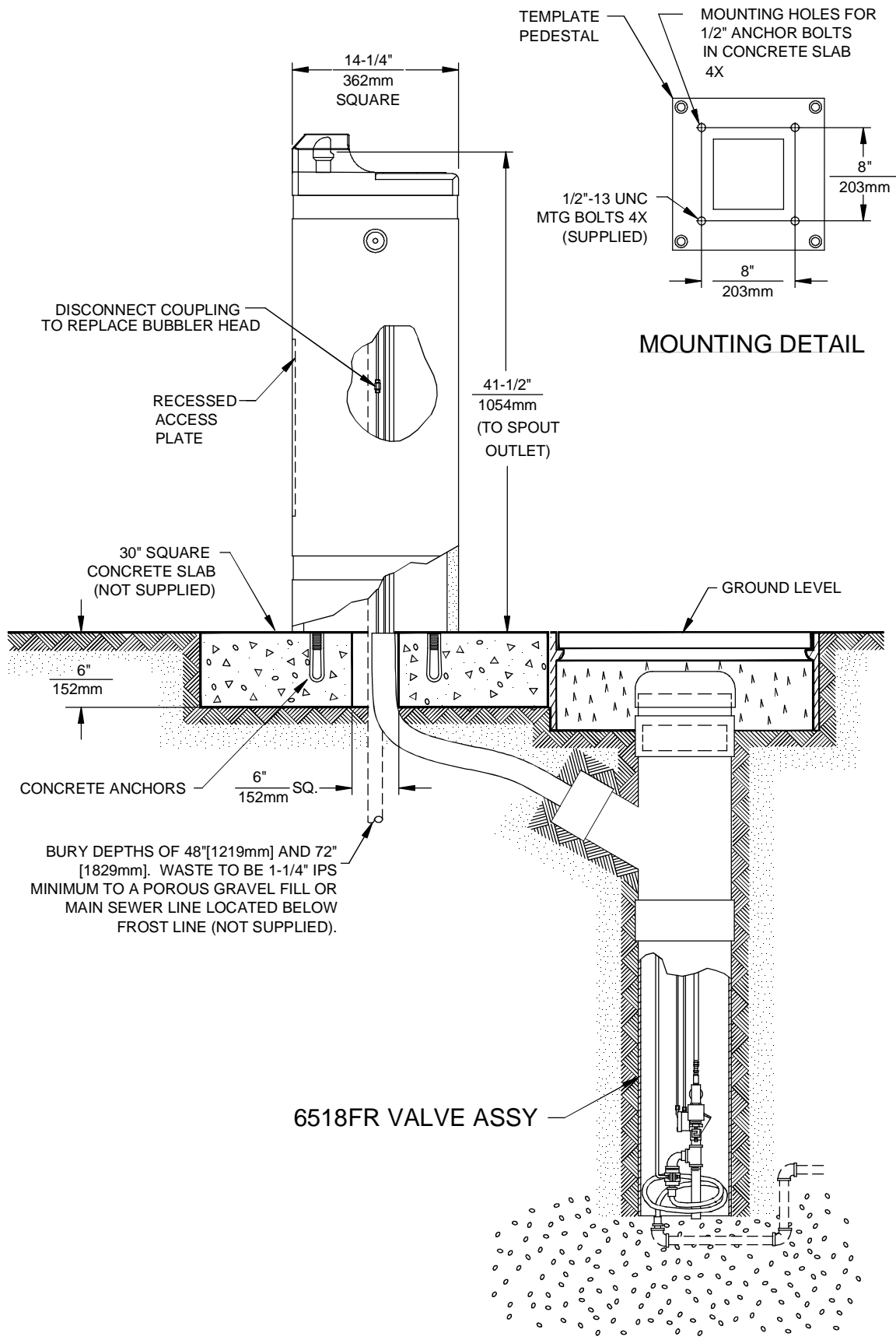

BURY DEPTHS OF 48"[1219mm] AND 72"  
[1829mm]. WASTE TO BE 1-1/4" IPS  
MINIMUM TO A POROUS GRAVEL FILL OR  
MAIN SEWER LINE LOCATED BELOW  
FROST LINE (NOT SUPPLIED).



1455 KLEPPE LANE  
SPARKS, NEVADA 89431  
(775) 359-4712 FAX (775) 359-7424  
E-MAIL: HAWS@HAWSCO.COM  
WEBSITE: WWW.HAWSCO.COM

ECNNO	REVISED PER BY:	MODEL(S)	PART NUMBER
DRAWN:	ECN:4556	HM	0002077064.D
CHKD:	DATE: 9/29/92	VWC	REVISION
APPROVED:	DATE: 04/21/15	SCALE: 1:1	SHEET 1 OF 1
FV	DATE:	DRAWING TYPE: INSTALLATION	
		SIZE: A	