



# INSTALLATION, OPERATION & MAINTENANCE INSTRUCTIONS

1455 Kleppe Lane ♦ Sparks, NV 89431-6467 ♦ (775) 359-4712 ♦ Fax (775) 359-7424  
E-mail: [haws@hawsco.com](mailto:haws@hawsco.com) ♦ website: [www.hawsco.com](http://www.hawsco.com)

No. 2076988(13)

## Model 1501 Drinking Fountain

**NOTE TO INSTALLER: Please leave this information with the Maintenance Department.**

### LIMITED WARRANTY

HAWS warrants that this specific product is guaranteed against defective material or poor workmanship for a period of **one year from date of shipment**. HAWS liability under this warranty shall be discharged by furnishing without charge F.O.B. HAWS Factory any goods, or part thereof, which shall appear to the Company upon inspection to be of defective material or not of first class workmanship, provided that claim is made in writing to Haws within a reasonable period after receipt of the product. Where claims for defects are made, the defective part or parts shall be delivered to the Company, prepaid, for inspection. HAWS will not be liable for the cost of repairs, alterations or replacements, or for any expense connected therewith made by the owner or his agents, except upon written authority from HAWS, Sparks, Nevada. HAWS will not be liable for any damages caused by defective materials or poor workmanship, except for replacements, as provided above. Buyer agrees that HAWS shall not be liable for general, special, or consequential damages claimed to arise under the contract of sale. The drinking fountain manufactured by HAWS is warranted to function if installation and maintenance instructions provided are adhered to. The units also must be used for the purpose for which they were intended.

**NO OTHER WARRANTIES EXPRESSED OR IMPLIED ARE AUTHORIZED,  
PROVIDED OR GIVEN BY HAWS.**

**SHOULD YOU EXPERIENCE DIFFICULTY WITH THE INSTALLATION OF THIS  
MODEL PLEASE CALL:**

**TECHNICAL SUPPORT: 1-800-766-5612**

**FOR CUSTOMER SERVICE: 1-888-640-4297**

**RECOMMENDED TOOLS:** Hack saw, pipe joint sealant, screwdriver, level, 12" adjustable wrench, 10" pipe wrench, 5/64" hex key wrench, 9/16", 1/2", 7/16" socket wrench or open end wrench.

**LOCATION OF UNIT:** The Model 1501 Drinking Fountain is a wheelchair accessible drinking water facility. The height dimensions shown, meet current ADA requirements. When installing this unit, local, state or federal codes should be adhered to. If height other than shown is required, then dimensions must be adjusted accordingly.

**SUPPLY LINE:** The minimum recommended line size is 1/2" IPS with 30-90 psi (2-6 ATM) flowing pressure. Where sediment or mineral content is a problem, an inlet filter is recommended.

**PLUMBING CONNECTIONS:** Inlet is 3/8" O.D. tubing fitting. Waste trap outlet is 1-1/4" IPS.

**MAINTENANCE:** Periodically clean the strainer. Refer to 5874SS Valve Manual for more information.

## INSTALLATION PROCEDURE

### GENERAL NOTES:

1. For all plastic push-in type fitting connections, only connect NSF-61 copper or plastic tubing. Stainless steel or glass tubing is not recommended. The following assembly instructions must be followed to ensure a watertight connection:
  - a. Cut tubing square and clean.
  - b. Mark from end of tube the length of insertion (See table below).
  - c. Push tube into the fitting until it bottoms out.
  - d. To remove, depress collet and pull tubing out.

Tube Sizes	O.D. Tolerance	Insertion Depth
1/4"	±.005"	11/16"
3/8"	±.005"	3/4"
1/2"	±.005"	7/8"

Refer to Installation Drawing for mounting height. For steps below, refer to exploded view.

**STEP 1:** Remove hex lock nut and washers from bubbler heads, set aside. Install bubbler heads through receptor. Install respectively rubber washer, fiber washer, then nut onto bubbler shank. Securely tighten nut.

**STEP 2:** Remove push button assembly from 5874SS valves with spanner wrench provided. Be sure to also remove (chrome plated) ring nut and (chrome plated) washer from valves. At this point, carefully follow installation instructions shown on page 5 of 5 of **5874SS Valve/Push Button Operation and Maintenance Manual** under heading: **"INSTALLATION INSTRUCTIONS FOR 5874SS W/PBA7"**

## INSTALLATION PROCEDURE

- STEP 3:** Make tubing connections from bubbler to the outlet side of control valve. Follow instructions for tubing preparation and insertion depths from Step 3.
- STEP 4:** Place strainer into receptor (using putty), secure in place using a fiber washer and lock nut.
- STEP 5:** Mount fountain with back panel to mounting plate using 3/8-16 hardware (provided).
- STEP 6:** Flush supply line to clear debris. Connect to a 1/2" NPT supply line and tighten.
- STEP 7:** Make certain that fountain is level and well secured to wall. Connect waste trap to a 1-1/4" IPS waste pipe (to be supplied by customer).
- STEP 8:** Completely open the screwdriver stop (not supplied) and check for leaks.
- STEP 9:** Adjust valves for desired flow height. See 5874SS Valve Manual (supplied).
- STEP 10:** Attach bottom plates to fountain using #10-24 hardware provided.

<b>TROUBLESHOOTING</b>	
<b>PROBLEM</b>	<b>REPAIR CHECKLIST</b>
1. Insufficient bubbler flow.	1a. Check that inlet screwdriver stop valve is in wide-open position. 1b. Verify minimum 30 psi flowing supply pressure. 1c. Clean strainer. See 5874SS Valve Manual. 1d. Adjust valve to increase flow. Use front adjust screw or see 5874SS Valve Manual.

For more information on Haws products, see our website: [www.hawsc.com](http://www.hawsc.com)

# PARTS BREAKDOWN

NOTES:

- 1 CONNECT CLEAR "POLYETHYLENE" TUBING ON FREE FLOW SIDE (VALVE TO BUBBLER HEAD) ONLY.
- 2 REFER TO 5874SS OPERATION AND MAINTENANCE MANUAL FOR INSTALLATION INSTRUCTIONS.
- 3 MUST APPLY 1 DOT OF LOCTITE 222MS THREADLOCKER ON FEMALE THREADS OF PUSH BUTTON. SEE 5874SS OPERATION AND MAINTENANCE MANUAL (PAGE 5 OF 5) FOR PROPER APPLICATION PROCEDURE.
- 4 SEE VIEW B FOR ALTERNATE PARTS SUPPLIED WITH OPTIONAL 1501TRIMCA.
- 5 1501TRIMCA REPLACES THE STANDARD BOTTOM PLATE, PN PBM1311, AND 1 1/4 X 1 3/4 TAILPIECE, PN 0005743542, WITH BOTTOM PLATE, PN 0004544799, AND S-SHAPED WASTE BEND, PN 0000198950, ON THE BOTTOM RIGHT FOUNTAIN ONLY. (STANDARD PARTS ARE STILL USED ON THE TOP LEFT FOUNTAIN.)
- 6 1501TRIMCA ALSO REPLACES THE STANDARD PAINTED BACK PANEL, PN 0004012247, WITH PAINTED BACK PANEL, PN 0004012251 (NOT SHOWN).

**DRIVER, NOZZLE  
.25 HEX PN  
0002082253  
(OPTIONAL) FOR  
REMOVAL OF  
NOZZLE WITH TUBE**



**VIEW A  
ROTATED 90° CCW  
DETAIL OF 5703M**

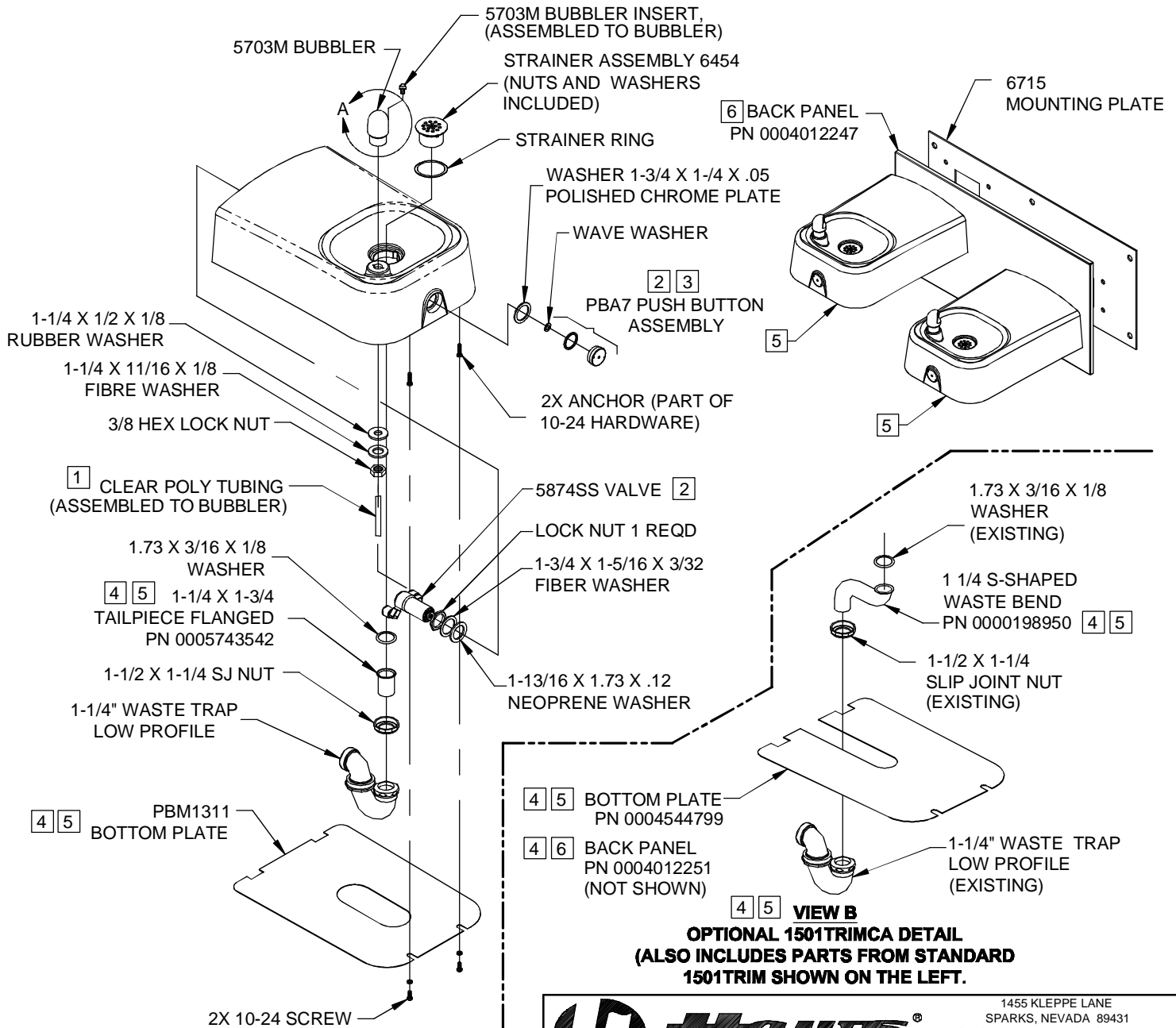

**VIEW B  
OPTIONAL 1501TRIMCA DETAIL  
(ALSO INCLUDES PARTS FROM STANDARD  
1501TRIM SHOWN ON THE LEFT.)**

		1455 KLEPPE LANE SPARKS, NEVADA 89431 (775) 359-4712 FAX (755) 359-7424 E-MAIL: HAWS@HAWS.CO.COM WEBSITE: WWW.HAWS.CO.COM	
ECN NO.	REVISED PER	BY	MODEL(S)
	ECN: 5028	FV	1501
DRAWN	DATE	CHKD	PART NUMBER
A DAY	05/01/01		0002076988
APPROVED	DATE		DRAWING NO.
FV	08/24/15		0002076988
SCALE: 1:6		DRAWING TYPE: PARTS BREAKDOWN	SIZE: A SHEET 1 OF 1

WHEN ORDERING PARTS PLEASE SPECIFY MODEL NUMBER.



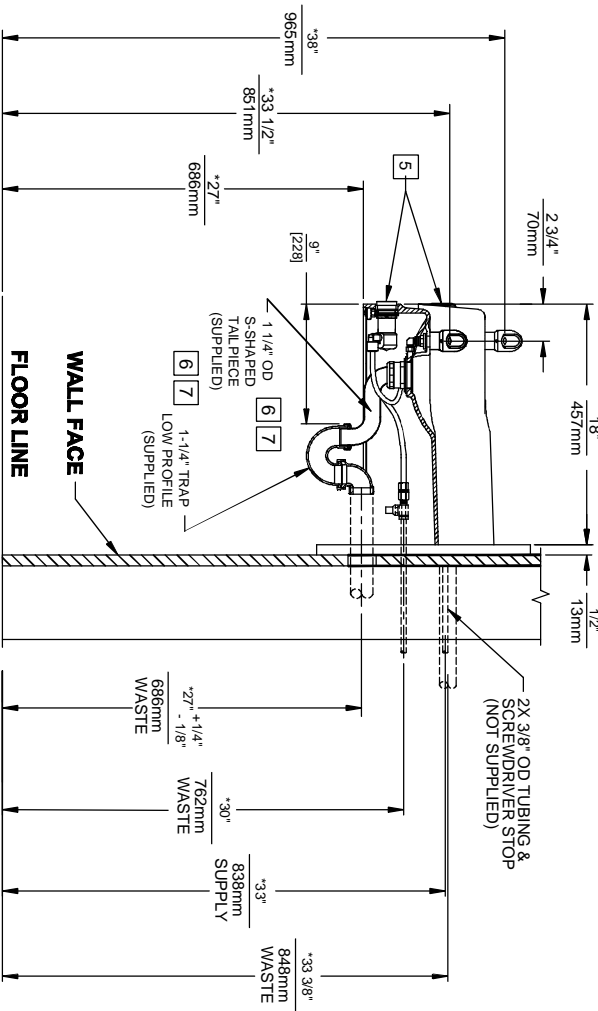
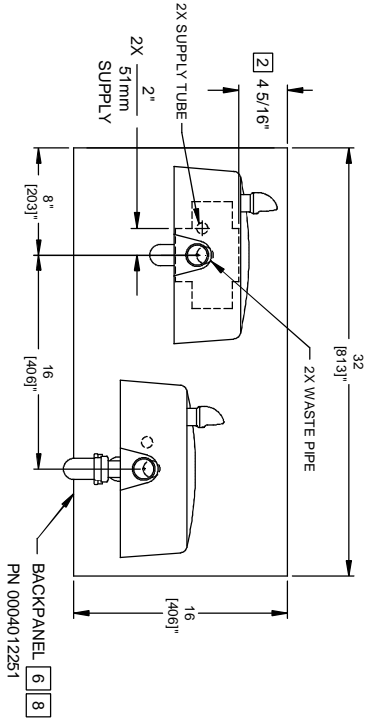
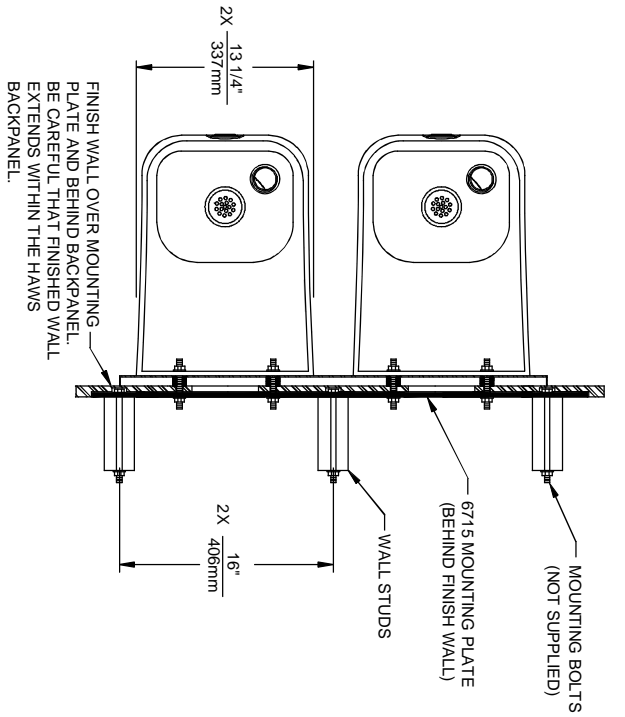

**6 7 8 1501TRIMCA**  
(ALTERNATE INSTALLATION)



**Haws**

1455 KLEPPE LANE  
SPARKS, NEVADA 89431  
(775) 359-4712 FAX (755) 359-7424  
E-MAIL: HAWS@HAWSCC.COM  
WEBSITE: WWW.HAWSCC.COM

EDGING REQUIRED REFER BY:	FV	MODEL(S)	1501
DRAWING DATE:	05/15/01	DRAWING TYPE:	INSTALLATION
APPROVED:	FV	SCALE:	1:14
DATE:	08/24/15	SHEET:	2 OF 2
PART NUMBER:	0002076988.D	DRAWING NO.:	14939A00
REV:	13		