

FEATURES & BENEFITS

CONSTRUCTION

Stainless steel basin with a high-polished finish compliments almost any setting, and it also resists stains and corrosion.

MOUNTING

Wall-mounted design makes for a space install, supported by a cast-aluminum wall bracket.

BUBBLER VALVE

Polished stainless steel cartridge valve which allows for top access stream adjustment as well as cartridge and strainer access, and is designed with a shielded, anti-squirt orifice that provides a steady sanitary source of water.



OPTIONS

- Valve Repair Kit: Model VRK5010, valve repair kit that includes the cartridge assembly, screen and washer.
- Water Filter: Model 6426, 12" x 2" (30.5 x 5.1 cm), in-line lead removal element that reduces lead from incoming water supply.

To see all options for this model, visit www.hawscos.com

SPECIFICATIONS

Model 1152 wall mounted drinking fountain shall include a polished stainless steel round basin, polished stainless steel push-button bubbler valve with flow adjustment, anodized cast-aluminum wall bracket, 100% lead-free waterways, and chrome-plated 1-1/4" O.D. tailpiece.

APPLICATIONS

Perfect for either public or private settings, Model 1152 drinking fountain is great for those looking to obtain a full functioning fountain with a simplistic design. Unit fits nicely into campground settings and other environments that are in more remote areas where drinking fountain facilities are still needed. Corrosion resistant stainless steel bowl and push button valve with adjustable stream makes for just the right combination of protection and adjustability needed in a basic fountain. Haws manufactures drinking fountains and electric water coolers to be lead-free by all known definitions including NSF/ANSI Standard 61, Section 9, NSF/ANSI 372, California Proposition 65, and the Federal Safe Drinking Water Act. Product is compliant to California Health and Safety Code 116875 (AB 1953-2006).

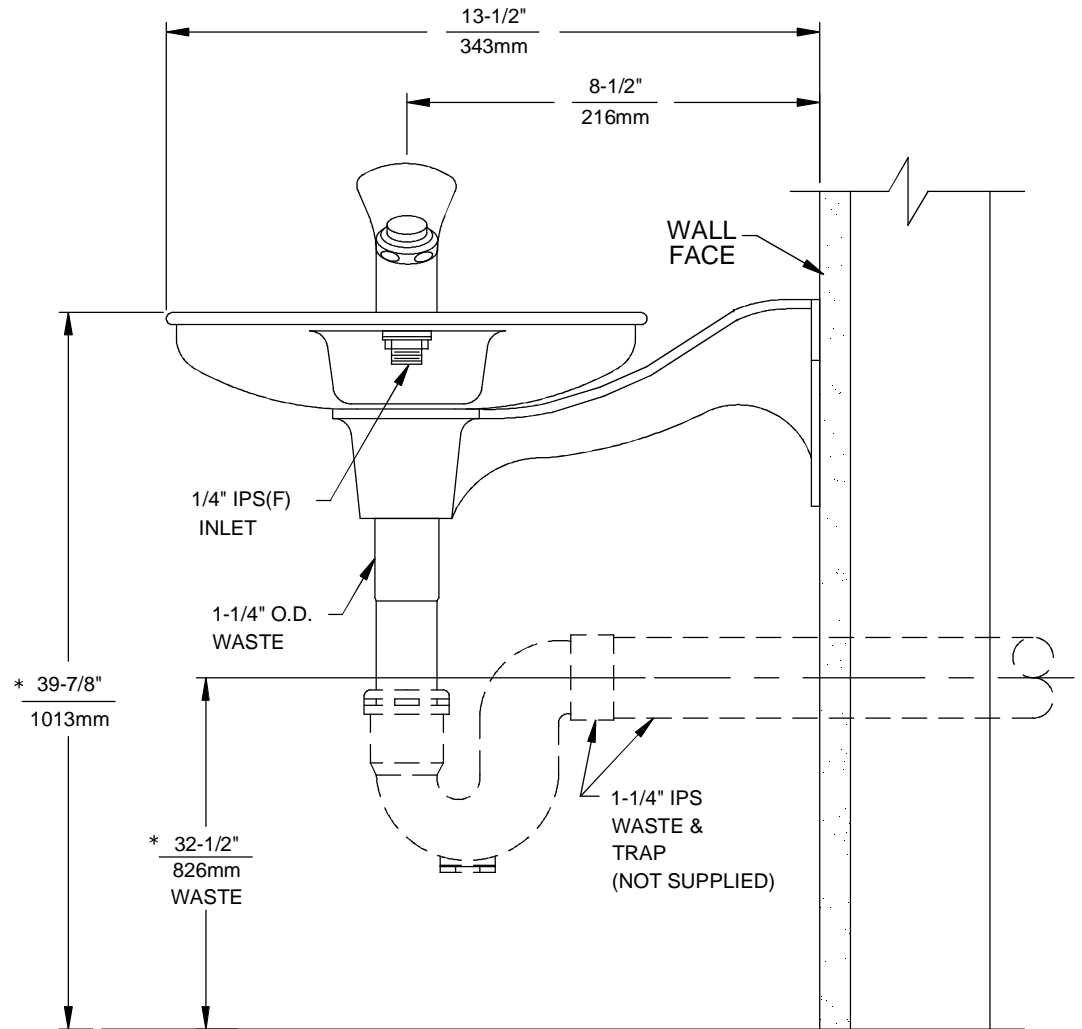
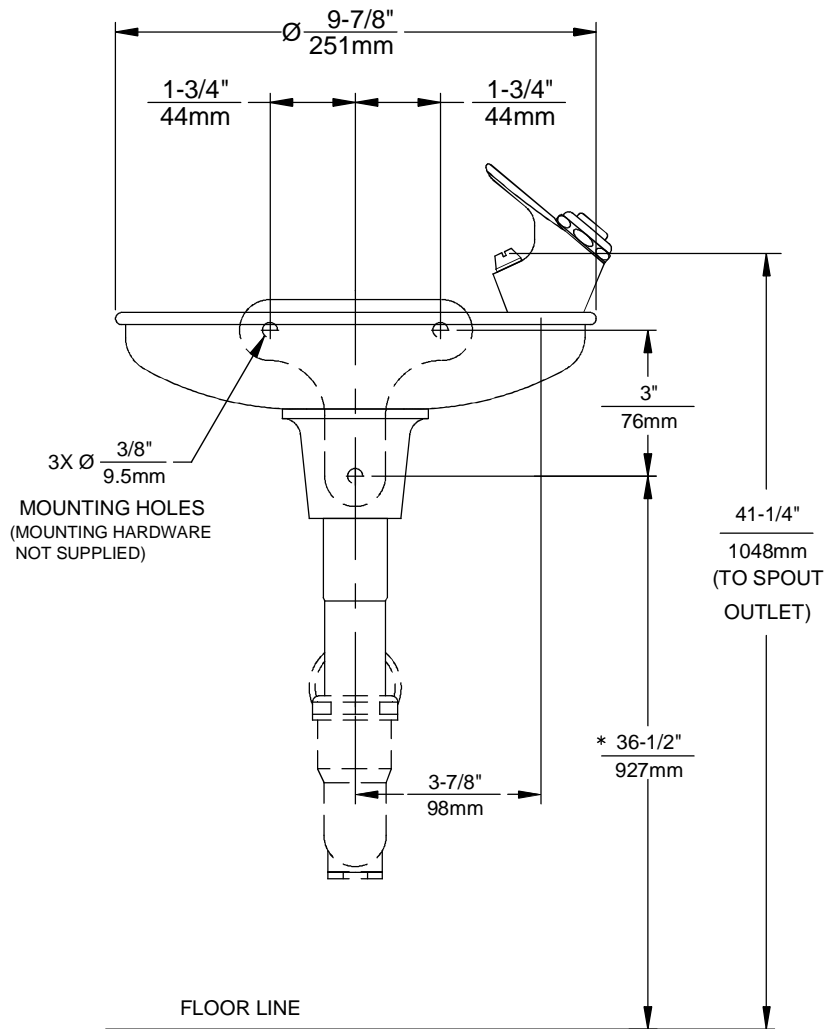

NOTES:

1. ROUGH-IN DIMENSIONS MAY VARY \pm 1/4" (6.4mm).
2. WHEN INSTALLING THIS UNIT, LOCAL, STATE OR FEDERAL CODES SHOULD BE ADHERED TO FOR INSTALLATION DIMENSIONS (LOCATIONS), WASTE AND SUPPLY REQUIREMENTS OTHER THAN SHOWN.

		1455 KLEPPE LANE SPARKS, NEVADA 89431 (775) 359-4712 FAX (755) 359-7424 E-MAIL: HAWS@HAWS.CO.COM WEBSITE: WWW.HAWS.CO.COM	
		ECN NO. REVISED PER BY: ECN: 4910 HM DRAWN: DATE: CHKD.: C. HAYES 05/91 APPROVED: DATE:	MODEL(S) 1152
SCALE: 1:1		DRAWING TYPE: INSTALLATION	SIZE: A SHEET 1 OF 1