



model 1119

Barrier-Free Dual Wall Mount Fountain

FEATURES & BENEFITS

CONSTRUCTION

Unit is made of 18 gauge Type 304 stainless steel with a satin finish that resists stains and corrosion, and has soft, rounded corners. Unit features stainless steel satin finish back panel, vandal-resistant bottom plate, and 1-1/4" integral trap.

INTEGRATED TRAP

Chrome-plated 1-1/2" IPS trap is internally mounted for easy access and installation.

QUALITY CONTROL

Both fountains are pre-built and fully water and pressure tested to ensure proper functionality.

BACK PANEL

Stainless steel back panel helps to protect the wall from inadvertent splashing, and its decorative satin finish increases location visibility and completes the fountains attractive appearance.

BARRIER-FREE

Barrier-free capabilities combined with its ease of use allows for a number of installation location possibilities.

BUBBLER HEAD

Polished chrome-plated brass bubbler head with integral basin shank for added strength. Shielded, angled stream opening provides a steady, sanitary source of drinking water.

PUSH BUTTON VALVE

The push-button activated valve assembly allows for front access stream adjustment as well as cartridge and strainer access. The valve works at an operating pressure range of 30 to 90 psi (2.1 to 6.2 bar).



SPECIFICATIONS

Model 1119 "Hi-Lo" wall mounted barrier-free drinking fountain shall include dual 18 gauge Type 304 Stainless Steel satin finish basins, push-button operated stainless steel valves with front-accessible cartridge and flow adjustment, 100% lead-free waterways, polished chrome-plated brass vandal-resistant bubbler heads, polished chrome-plated brass vandal-resistant waste strainers, vandal-resistant bottom plates, stainless steel satin finish back panel, high and low fountain mounting levels, and 1-1/4" IPS traps.

APPLICATIONS

Perfect for either public or private indoor/outdoor settings, Model 1119 is a great fit in areas where aesthetics are important to the overall appeal of the architecture. This series is precisely mounted, making it a nice addition to any surrounding. Beautiful satin finish helps to maintain the fountains overall appeal so it always remains looking as new as it did when it was installed. Specifically, this type of wall mounted drinking fountain may be placed in settings such as: schools and other locations in and around office buildings where the temperature remains above freezing. Model meets all current Federal Regulations for the disabled including those in the Americans with Disabilities Act. Haws manufactures drinking fountains and electric water coolers to be lead-free by all known definitions including NSF/ANSI Standard 61, Section 9, NSF/ANSI 372, California Proposition 65, and the Federal Safe Drinking Water Act. Product is compliant to California Health and Safety Code 116875 (AB 1953-2006).

OPTIONS

- ❑ Fountain Skirt: Model SK1, satin finish stainless steel cane touch skirt for installation on high unit to comply with ADA protruding objects guidelines.
- ❑ Water Filter: Model 6426, 12" x 2" (30.5 x 5.1 cm), in-line lead removal element that reduces lead from incoming water supply.
- ❑ Mounting Plate: Model 6700.4 "Hi-Lo" universal mounting plate for most dual bubbler fountains. Priced Separately
- ❑ Support Frame: Model 6800 universal in-wall mounting support for use with most fountains.

To see all options for this model, visit www.hawsc.com



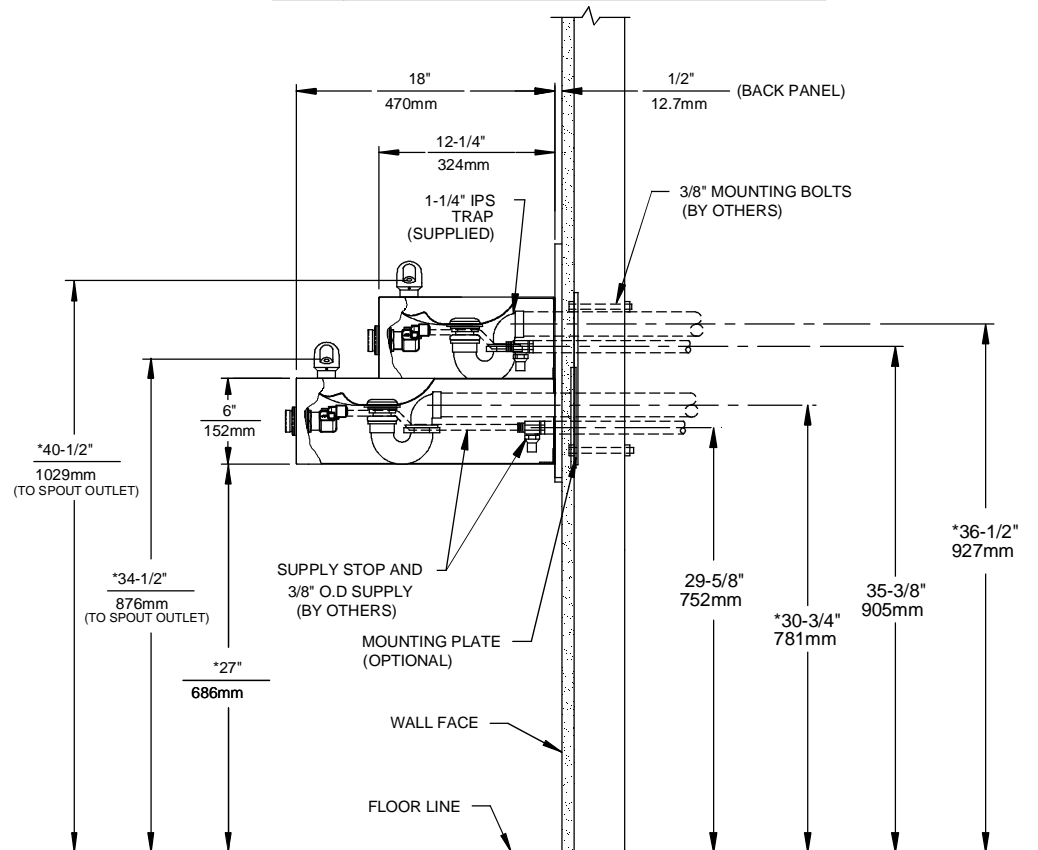
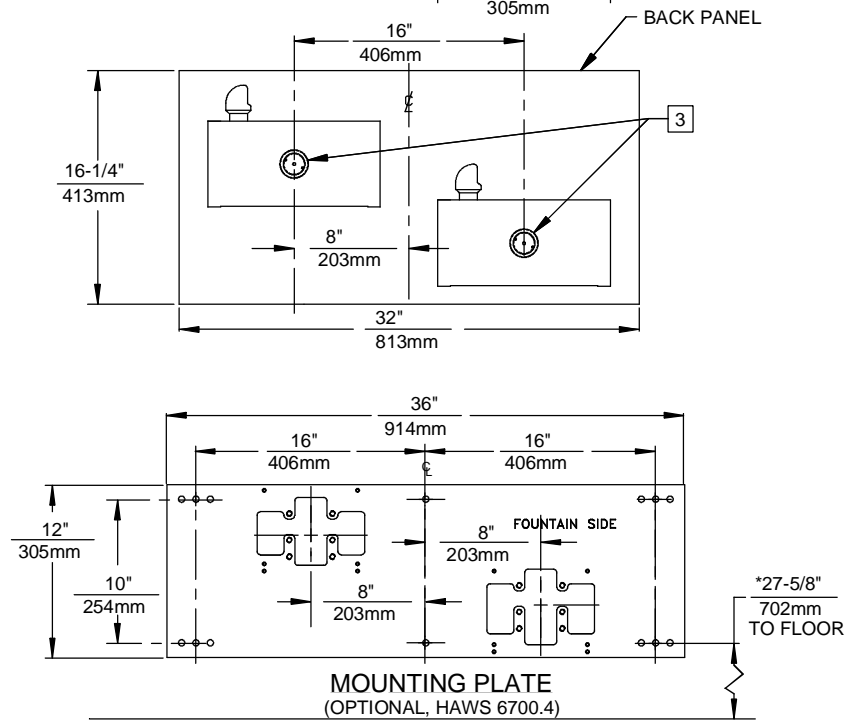
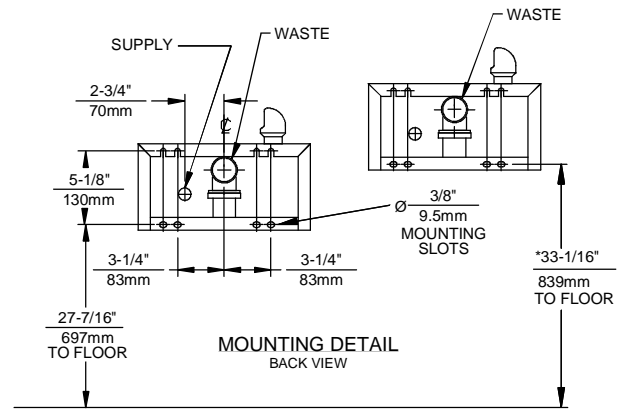
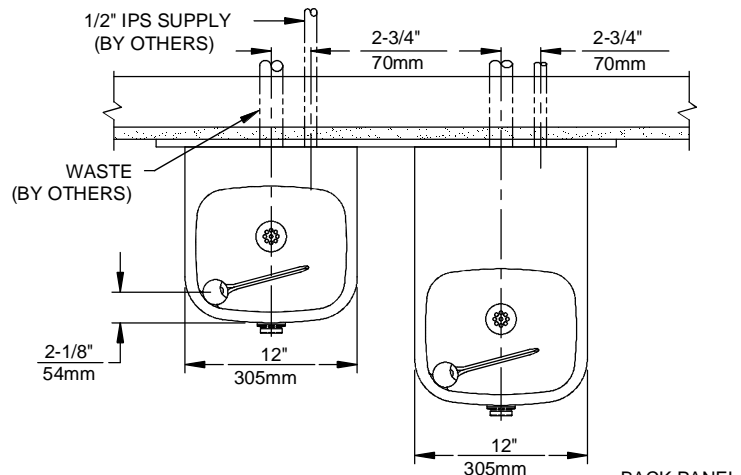

NOTES:

1. HOLD ROUGH-IN DIMENSIONS ± 1/4" (6.4mm).
2. WHEN INSTALLING THIS UNIT, LOCAL, STATE, OR FEDERAL CODES SHOULD BE ADHERED TO. FOR INSTALLATION HEIGHTS OTHER THAN SHOWN, DIMENSIONS MARKED (*) MUST BE ADJUSTED ACCORDINGLY.
- 3 REFER TO 5874SS/VRK5874 OPERATION AND MAINTENANCE MANUAL FOR PUSH BUTTON AND VALVE INSTALLATION/MAINTENANCE INSTRUCTONS.

| | | | |
|--|-----------------|---|--|
| | | 1455 KLEPPE LANE SPARKS, NEVADA 89431 (775) 359-4712 FAX (775) 359-7424 E-MAIL: HAWS@HAWSCO.COM WEBSITE: WWW.HAWSCO.COM | |
| | | ECN NO. REVISED PER BY: ECN: 4797 HM MODEL(S) 1119 | PART NUMBER: 0002076716.D DRAWING NO.: 13538C00 REV: 17 |
| DRAWN: F. VASQUEZ DATE: 04/15/98 APPROVED: | DATE: CHK'D: | SCALE: 1:13 DRAWING TYPE: INSTALLATION | SIZE: A SHEET 1 OF 1 |