



# model 1109.14

Barrier-Free Wall Mount Fountain

## FEATURES & BENEFITS

### INTEGRATED TRAP

Chrome-plated 1-1/2" IPS trap is internally mounted for easy access and installation.

### QUALITY CONTROL

Pre-built fountain pressure tested to ensure no leaks and proper functionality.

### BUBBLER HEAD

Polished chrome-plated brass bubbler head with integral basin shank for added strength. Shielded, angled stream opening provides a steady, sanitary source of drinking water.

### CONSTRUCTION

One-piece stamped basin made of 14 gauge Type 304 stainless steel with a satin finish that resists stains and corrosion, with soft, rounded corners. Unit has an integral 1/4" (.6 cm) stainless steel mounting plate, vandal-resistant bottom plate, and 1-1/4" NPT trap.

### PUSH BUTTON VALVE

The push-button activated valve assembly allows for front access stream adjustment as well as cartridge and strainer access. The valve works at an operating pressure range of 30 to 90 psi (2.1 to 6.2 bar).



## SPECIFICATIONS

Model 1109.14 is a wall mounted, barrier-free drinking fountain with 14 gauge Type 304 Stainless Steel with satin finish, push-button operated stainless steel valve with front accessible cartridge and flow adjustment, 100% lead-free waterways, polished chrome-plated brass bubbler head and waste strainer, integral 1/4" (.6 cm) stainless steel mounting plate, vandal-resistant bottom plate and 1-1/4" NPT trap.

## OPTIONS

- ❑ Back Panel: Model BP3, satin finish stainless steel back panel.
- ❑ Water Filter: Model 6426, 12" x 2" (30.5 x 5.1 cm), in-line lead removal element that reduces lead from incoming water supply.
- ❑ Mounting Plate: Model 6700 universal mounting plate for most wall mounted fountains. Priced Separately
- ❑ Support Frame: Model 6800 universal in-wall mounting support for use with most fountains.

To see all options for this model, visit [www.hawsc.com](http://www.hawsc.com)

## APPLICATIONS

Perfect for either public or private indoor/outdoor settings, Model 1109.14 is a great fit in areas where aesthetics are important to the overall appeal of the architecture. Suitable in areas where extra durability is needed, thicker gauged steel is implemented so this unit mounts solidly from any wall. Beautiful satin finish helps to maintain the fountains overall appeal so it always remains looking as new as it did when it was installed. Specifically, this type of wall mounted drinking fountain may be placed in settings such as: schools and other locations in and around office buildings where the temperature remains above freezing. Model meets all current Federal Regulations for the disabled including those in the Americans with Disabilities Act. Haws manufactures drinking fountains and electric water coolers to be lead-free by all known definitions including NSF/ANSI Standard 61, Section 9, NSF/ANSI 372, California Proposition 65, and the Federal Safe Drinking Water Act. Product is compliant to California Health and Safety Code 116875 (AB 1953-2006).



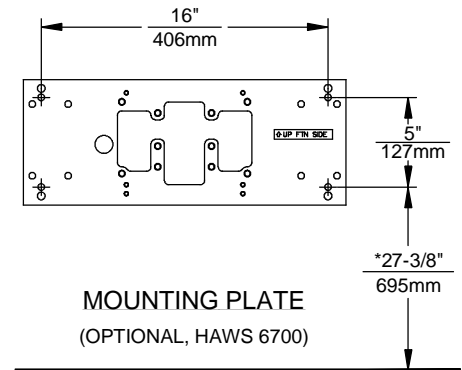
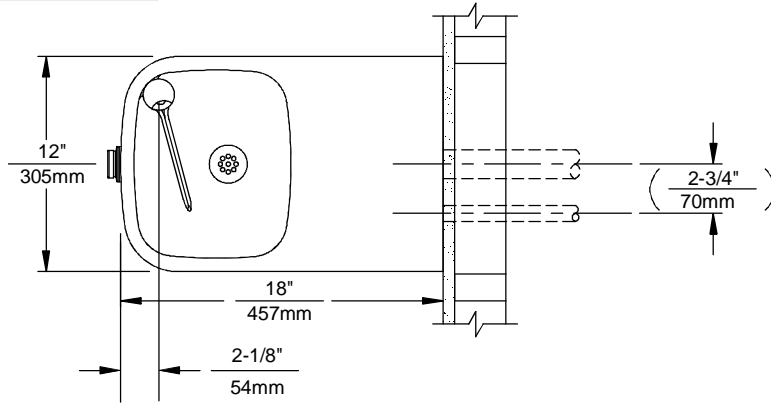

**MOUNTING PLATE**  
(OPTIONAL, HAWS 6700)

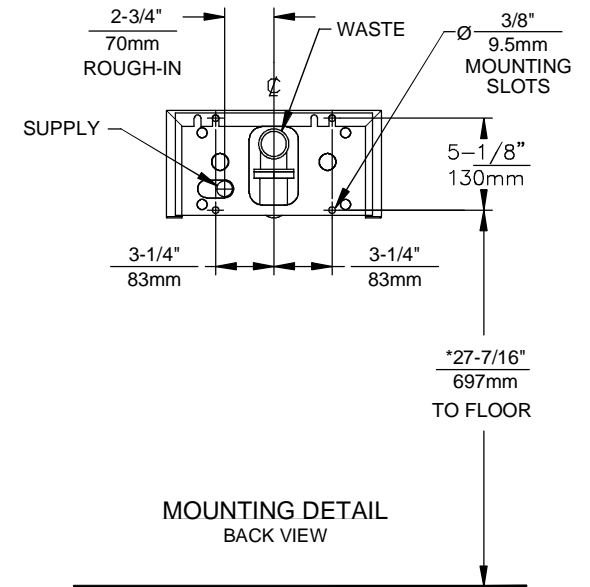
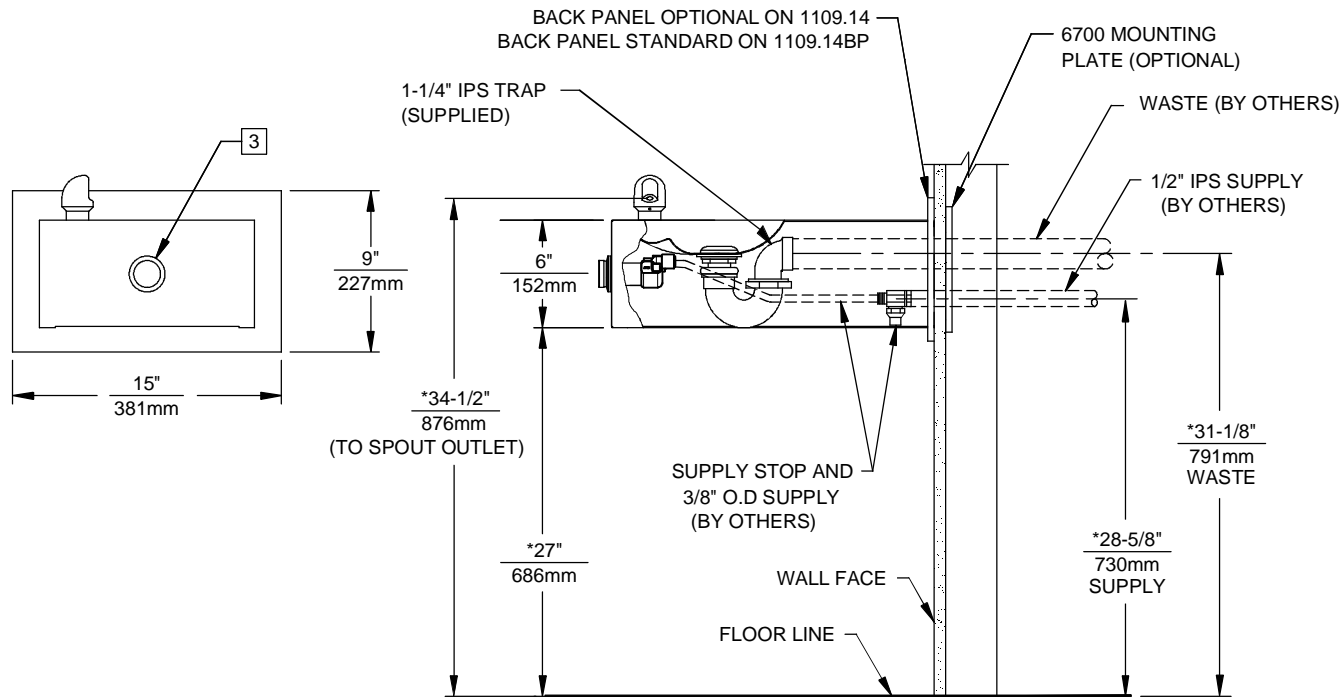

**MOUNTING DETAIL**  
BACK VIEW

**NOTES:**

- HOLD ROUGH-IN DIMENSIONS  $\pm 1/4"$  (6.4mm).
  - WHEN INSTALLING THIS UNIT, LOCAL, STATE OR FEDERAL CODES SHOULD BE ADHERED TO. FOR INSTALLATION HEIGHTS OTHER THAN SHOWN, DIMENSIONS MARKED (\*) MUST BE ADJUSTED ACCORDINGLY.
- 3 REFER TO 5874SS/VRK5874 OPERATION AND MAINTENANCE MANUAL FOR PUSH BUTTON AND VALVE INSTALLATION/MAINTENANCE INSTRUCTONS.

		1455 KLEPPE LANE SPARKS, NEVADA 89431 (775) 359-4712 FAX (755) 359-7424 E-MAIL: HAWS@HAWS.CO.COM WEBSITE: WWW.HAWS.CO.COM	
		ECN NO. REVISED PER BY: ECN: 4797 HM DRAWN: DATE: CHKD.: F. VASQUEZ 06/98 APPROVED: DATE:	MODEL(S) 1109.14/1109.14BP
SCALE: 1:1		DRAWING TYPE: INSTALLATION	SIZE: A SHEET 1 OF 1