



# model 1025

## Barrier-Free Steel Wall Mount Fountain

### FEATURES & BENEFITS

#### CONSTRUCTION

Barrier-free design made of heavy-duty 11 gauge galvanized steel with green powder-coat finish. Unit has a high-polished stainless steel basin that resists stains and corrosion, recessed push-button, welded bubbler guard, and vandal-resistant bottom plate.

#### DRAIN CLEAN-OUT

Top-down access to the drain allows the fountain to be cleaned without taking the unit apart, good for outdoor settings with drain-clogging sediment such as leaves, garbage, and other debris.

#### INTEGRATED TRAP

Chrome-plated 1-1/2" IPS trap is internally mounted for easy access and installation.

#### QUALITY CONTROL

Pre-built fountain pressure tested to ensure no leaks and proper functionality.

#### PUSH BUTTON VALVE

The push-button activated valve assembly allows for front access stream adjustment as well as cartridge and strainer access. The valve works at an operating pressure range of 30 to 90 psi (2.1 to 6.2 bar).



### OPTIONS

- Valve Repair Kit: Model VRK5874, valve repair kit for Model 5874.
- Outdoor Fountain Colors: Nine powder-coated colors, (green, silver, red, blue, black, brown, orange, yellow and white), available for an additional charge.
- Mounting Plate: Model 6700 universal mounting plate for most wall mounted fountains. Priced Separately
- Support Frame: Model 6800 universal in-wall mounting support for use with most fountains.

To see all options for this model, visit [www.hawSCO.com](http://www.hawSCO.com)

### SPECIFICATIONS

Model 1025 wall mounted barrier-free drinking fountain shall include a stainless steel basin contained in an 11 gauge green powder-coated galvanized steel wall bracket, push-button operated stainless steel valve with front-accessible cartridge and flow adjustment, polished chrome-plated brass vandal-resistant shielded bubbler head, 100% lead-free waterways, polished chrome-plated brass vandal-resistant waste strainer with top-down access, vandal-resistant bottom plate, and chrome-plated 1-1/2" IPS trap.

### APPLICATIONS

Perfect for either public or private outdoor settings, Model 1025 is a great fit in areas where aesthetics are important to the overall appeal of the architecture. Suitable in areas where weather conditions exist, this series is precisely mounted to make it a nice addition. Powder-coated finish help to maintain the fountains overall appeal so it always remains looking as new as it did when it was installed. Specifically, this type of wall mounted drinking fountain may be placed in settings such as: parks, schools, and other outdoor environments where the temperature remains above freezing. Model meets all current Federal Regulations for the disabled including those in the Americans with Disabilities Act. Haws manufactures drinking fountains and electric water coolers to be lead-free by all known definitions including NSF/ANSI Standard 61, Section 9, NSF/ANSI 372, California Proposition 65, and the Federal Safe Drinking Water Act. Product is compliant to California Health and Safety Code 116875 (AB 1953-2006) as evaluated by CSA International.



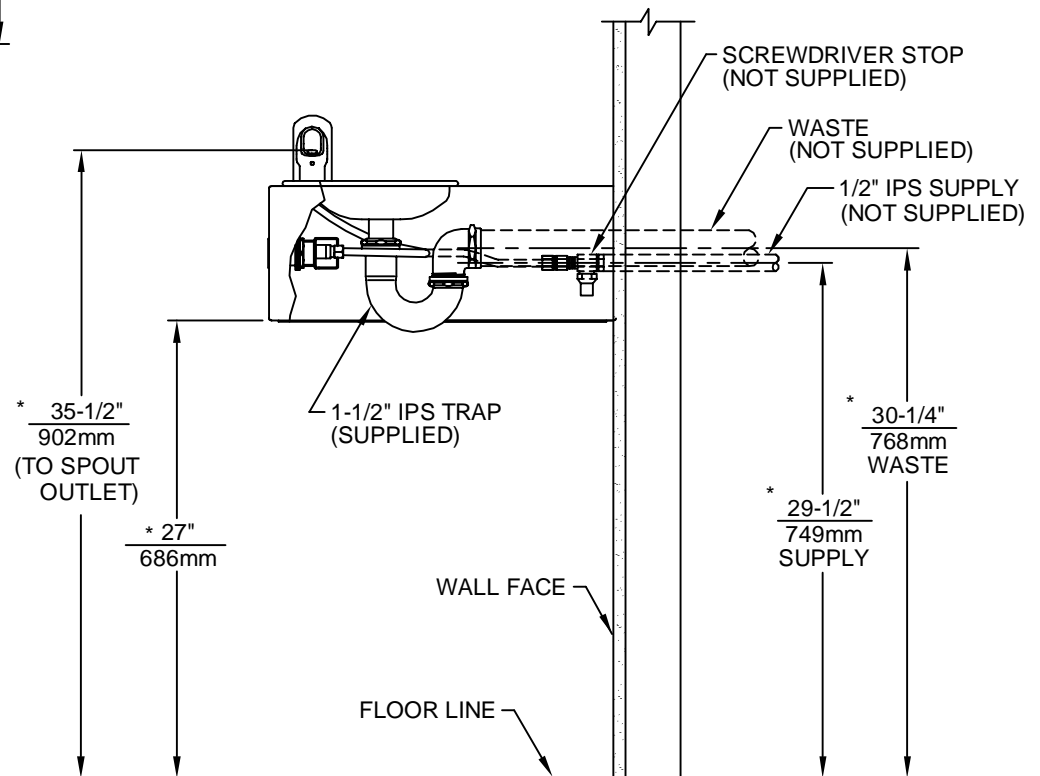
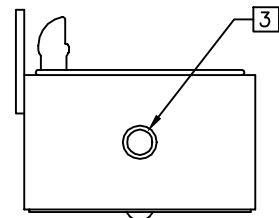
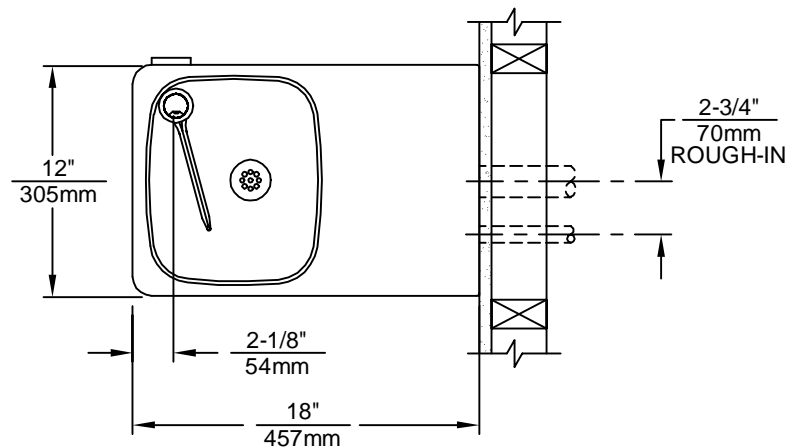
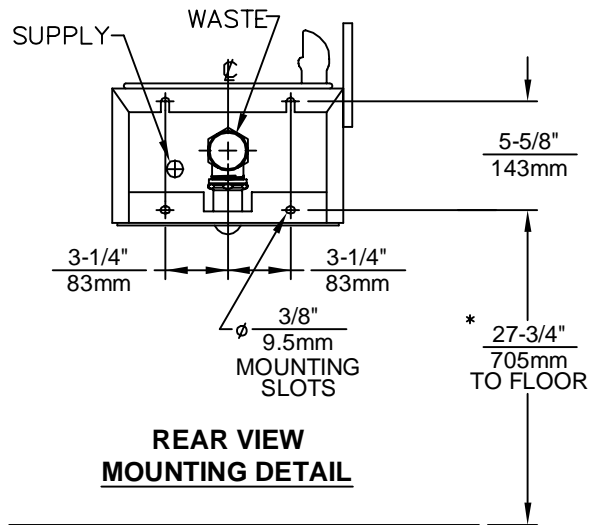

**NOTES:**

1. HOLD ROUGH-IN DIMENSIONS ±1/4" (6.4mm).
2. WHEN INSTALLING THIS UNIT LOCAL, STATE OR FEDERAL CODES SHOULD BE ADHERED TO. FOR INSTALLATION HEIGHTS OTHER THAN SHOWN, DIMENSIONS MARKED(\*) MUST BE ADJUSTED ACCORDINGLY.
3. REFER TO 5874SS OPERATION AND MAINTENANCE MANUAL FOR PUSH BUTTON AND VALVE INSTALLATION/ MAINTENANCE INSTRUCTIONS. (NOTE: THIS FOUNTAIN UTILIZES A HIGH FLOW CARTRIDGE TO ENSURE PROPER WATER FLOW).

		1455 KLEPPE LANE SPARKS, NEVADA 89431 (775) 359-4712 FAX (775) 359-7424 E-MAIL: HAWS@HAWSO.COM WEBSITE: WWW.HAWSO.COM	
ECN NO. REVISED PER ECN: 4620	BY: HJM	MODEL(S): 1025/1025G	PART NUMBER: 0002076415.D
DRAWN: C.J.L.	DATE: 09/92	INFO FAX DOC #: 21025/210254	DRAWING NUMBER: 10371C00
APPROVED:	DATE:	SCALE: 1:10	SHEET 1 OF 1