



model 1011MS

Barrier-Free Dual Wall Mount Fountain

FEATURES & BENEFITS

CONSTRUCTION

18 gauge Type 304 stainless Steel swirl design bowl, 14 gauge Type 304 Stainless Steel bracket, and a vandal-resistant bottom plate provides a long lasting unit with added peace of mind.

QUALITY CONTROL

Both fountains are pre-built and fully water and pressure tested to ensure proper functionality.

BACK PANEL

Stainless steel back panel helps to protect the wall from inadvertent splashing, and its decorative satin finish increases location visibility and completes the fountains attractive appearance.

MOUNTING

Galvanized frame and 10 gauge surface plate provide the maximum mounting strength for the 'Hi-Lo' MS style Haws drinking fountains.

BUBBLER HEAD

Polished chrome-plated brass bubbler head with integral laminar flow prevents splashing while providing a superior flow pattern. The integral basin shank and inserted roll pin add vandal resistance strength. Shielded, angled stream opening provides a steady, sanitary source of drinking water.

PUSH BUTTON VALVE

The push-button activated valve assembly allows for front access stream adjustment as well as cartridge and strainer access. The valve works at an operating pressure range of 30 to 90 psi (2.1 to 6.2 bar).



SPECIFICATIONS

Model 1011MS "Hi-Lo" wall mounted barrier-free drinking fountain shall include dual 18 gauge Type 304 Stainless Steel satin finish basins with integral swirl design, 14 gauge Type 304 Stainless Steel wall bracket, 100% lead-free waterways, push-button operated stainless steel valves with front-accessible cartridge and flow adjustment, polished chrome-plated brass vandal-resistant bubbler heads with integral laminar anti-squirt flow, chrome-plated brass vandal-resistant waste strainers, vandal-resistant bottom plates, stainless steel satin finish back and access panels allowing for front access of P-trap and stop, in-wall mounting frame, high and low fountain mounting levels, and 1-1/4" O.D. (3.2 cm) waste pipes. REQUIRES MODEL MTGFR.DF2 PRICED SEPARATELY.

OPTIONS

- Fountain Skirt: Model SK3, satin finish stainless steel cane touch skirt for installation on high unit to comply with ADA protruding objects guidelines.
- Water Filter: Model 6426, 12" x 2" (30.5 x 5.1 cm), in-line lead removal element that reduces lead from incoming water supply.
- Remote Chiller: Model HCR8, 8 gph (30.3 L) remote water chiller provides instantaneous cooling to meet a continuous demand for chilled water.

To see all options for this model, visit www.hawsc.com

APPLICATIONS

Perfect for either public or private indoor/outdoor settings, Model 1011MS is a great fit in areas where aesthetics are important to the overall appeal of the architecture. This series is precisely mounted, making it a nice addition to any surrounding. Beautiful satin finish helps to maintain the fountains overall appeal so it always remains looking as new as it did when it was installed. Specifically, this type of wall mounted drinking fountain may be placed in settings such as: schools and other locations in and around office buildings where the temperature remains above freezing. Model meets all current Federal Regulations for the disabled including those in the Americans with Disabilities Act. Haws manufactures drinking fountains and electric water coolers to be lead-free by all known definitions including NSF/ANSI Standard 61, Section 9, NSF/ANSI 372, California Proposition 65, and the Federal Safe Drinking Water Act. Product is compliant to California Health and Safety Code 116875 (AB 1953-2006) as evaluated by CSA International.



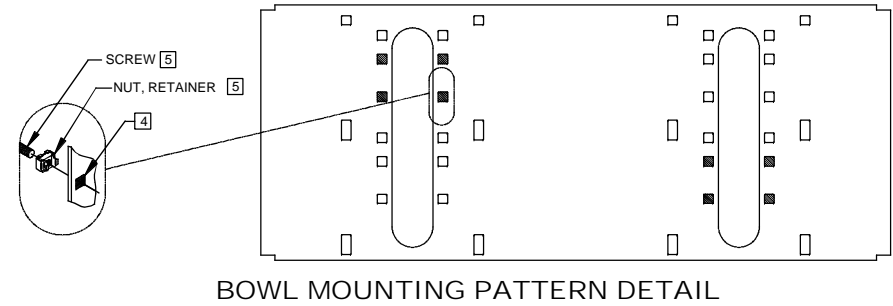
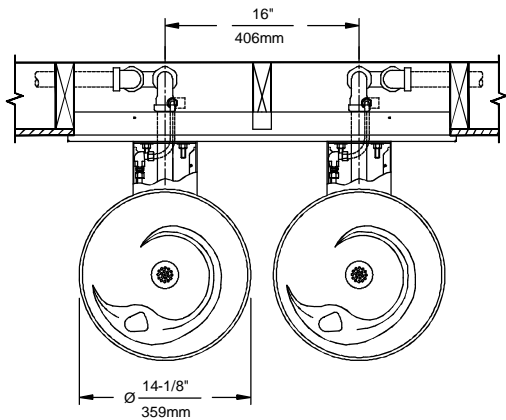

BOWL MOUNTING PATTERN DETAIL

NOTES:

1. HOLD ROUGH-IN DIMENSIONS $\pm 1/8"$ (3.2mm).
2. WHEN INSTALLING THIS UNIT, LOCAL, STATE, OR FEDERAL CODES SHOULD BE ADHERED TO FOR DIMENSIONS (LOCATIONS), WASTE AND SUPPLY REQUIREMENTS OTHER THAN SHOWN.
3. INSTALLER MUST PROVIDE TRAP FOR PROPER INSTALLATION.
4. HOLE COMBINATION SHOWN BELOW IS FOR USE WITH LOW FOUNTAIN ON THE RIGHT AND HIGH FOUNTAIN ON THE LEFT. USE OPPOSITE HOLES FOR HIGH ON RIGHT AND LOW ON LEFT.
5. TO CHANGE FOUNTAIN MTG. SCREW LOCATIONS: FIRST REMOVE SCREWS AND THEN SQUEEZE CLIPS ON NUT RETAINER TO POP OUT. SNAP INTO NEW POSITIONS FROM BACKSIDE AND RE-ASSEMBLE SCREWS.
6. IMPORTANT: A L.H. LOW (OPTIONAL) CONFIGURATION WILL REQUIRE A DIFFERENT BACK PANEL AND THE WASTE AND SUPPLY DIMENSIONS SHOWN (*) MUST BE REVERSED.
7. REFER TO 5874SS OPERATION AND MAINTENANCE MANUAL FOR PUSH BUTTON AND VALVE INSTALLATION/MAINTENANCE INSTRUCTIONS.

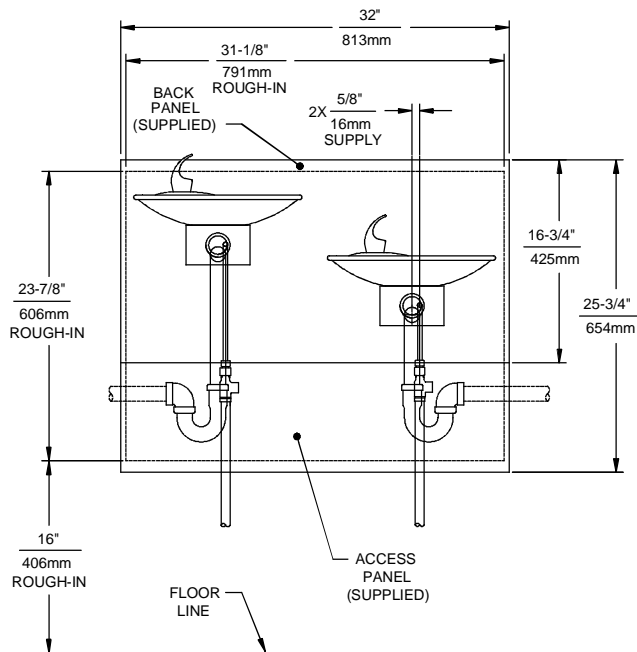

REMOVE VALVE FROM PUSH BUTTON TO INSTALL WASTE ELBOW ONTO BOWL. AFTER WASTE ELBOW IS INSTALLED, REINSTALL VALVE & ADJUST FLOW

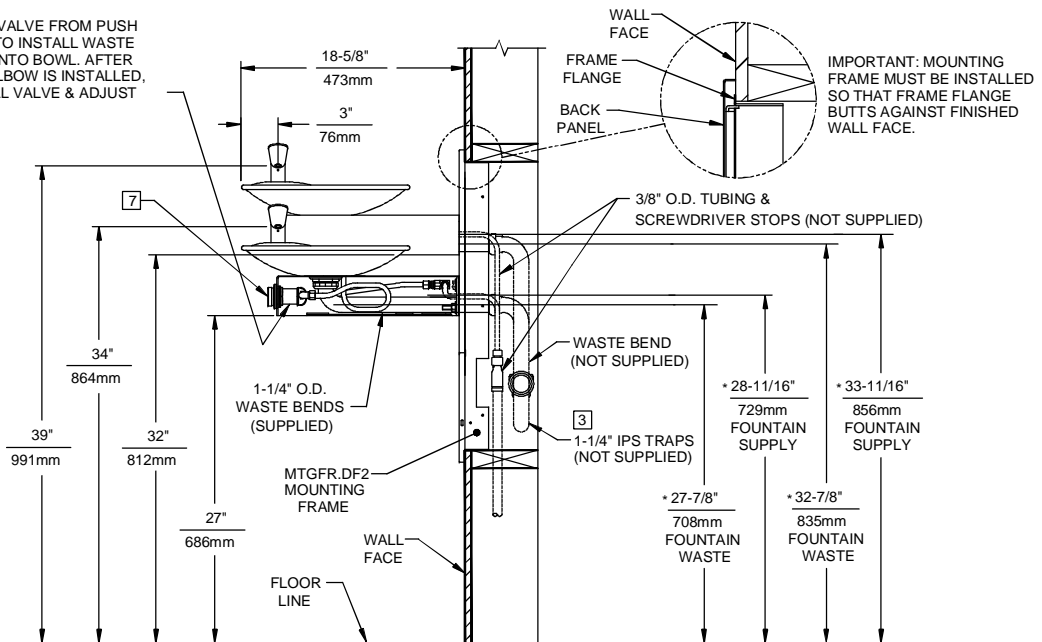

1455 KLEPPE LANE
SPARKS, NEVADA 89431
(775) 359-4712 FAX (755) 359-7424
E-MAIL: HAWS@HAWSCO.COM
WEBSITE: WWW.HAWSCO.COM

ECN NO. REVISED PER BY:	MODEL(S)	PART NUMBER
ECN: 4828 HM	1011HPSMS/1011MS	0002076519.D
DRAWN: PM	DATE: 08/02/99	CHKD.:
APPROVED:	DATE:	REV 14219C00 9
SCALE: 1:16	DRAWING TYPE: INSTALLATION	SHEET 1 OF 1