



model 1001HPS

Barrier-Free Wall Mount Fountain

FEATURES & BENEFITS

CONSTRUCTION

18 gauge Type 304 stainless Steel swirl design bowl, 14 gauge Type 304 Stainless Steel bracket, and a vandal-resistant bottom plate provides a long lasting unit with added peace of mind.

QUALITY CONTROL

Pre-built fountain pressure tested to ensure no leaks and proper functionality.

MOUNTING

3/16" (.47 cm) steel mounting plate with supplied mounting hardware for a solid unit base allows for easy installation to a framed wall. (P-trap and stop require rear access)

BUBBLER HEAD

Polished chrome-plated brass bubbler head with integral laminar flow prevents splashing while providing a superior flow pattern. The integral basin shank and inserted roll pin add vandal resistance strength. Shielded, angled stream opening provides a steady, sanitary source of drinking water.

PUSH BUTTON VALVE

The push-button activated valve assembly allows for front access stream adjustment as well as cartridge and strainer access. The valve works at an operating pressure range of 30 to 90 psi (2.1 to 6.2 bar).



OPTIONS

- Access Panel: Model 6603HPS, high polished stainless steel finish access panel. Includes frame and screws.
- Back Panel: Model BP6HPS, high polished stainless steel back panel.
- Water Filter: Model 6426, 12" x 2" (30.5 x 5.1 cm), in-line lead removal element that reduces lead from incoming water supply.
- Support Frame: Model 6800 universal in-wall mounting support for use with most fountains.

To see all options for this model, visit www.hawsco.com

SPECIFICATIONS

Model 1001HPS wall mounted barrier-free drinking fountain shall include an 18 gauge Type 304 high-polished stainless steel finish basin with integral swirl design, 14 gauge Type 304 high-polished stainless steel wall bracket, 100% lead-free waterways, push-button operated stainless steel valve with front-accessible cartridge and flow adjustment, polished chrome-plated brass vandal-resistant bubbler head with integral laminar anti-squirt flow, chrome-plated brass vandal-resistant waste strainer, vandal-resistant bottom plate, and 1-1/4" O.D. (3.2 cm) waste pipe. (P-trap and stop require rear access) REQUIRES MODEL 6700 PRICED SEPARATELY.

APPLICATIONS

Perfect for either public or private indoor/outdoor settings, Model 1001HPS is a great fit in areas where aesthetics are important to the overall appeal of the architecture. This series is precisely mounted, making it a nice addition to any surrounding. Beautiful high-polished finish helps to maintain the fountains overall appeal so it always remains looking as new as it did when it was installed. Specifically, this type of wall mounted drinking fountain may be placed in settings such as: schools and other locations in and around office buildings where the temperature remains above freezing. Model meets all current Federal Regulations for the disabled including those in the Americans with Disabilities Act. Haws manufactures drinking fountains and electric water coolers to be lead-free by all known definitions including NSF/ANSI Standard 61, Section 9, NSF/ANSI 372, California Proposition 65, and the Federal Safe Drinking Water Act. Product is compliant to California Health and Safety Code 116875 (AB 1953-2006).



NOTES:

1. HOLD ROUGH-IN DIMENSIONS $\pm 1/8"$ (3.2mm).
2. WHEN INSTALLING THIS UNIT, LOCAL, STATE, OR FEDERAL CODES SHOULD BE ADHERED TO FOR INSTALLATION DIMENSIONS (LOCATIONS), WASTE AND SUPPLY REQUIREMENTS OTHER THAN SHOWN.
3. INSTALLER MUST PROVIDE TRAP FOR PROPER INSTALLATION.
4. REMOVE VALVE FROM PUSH BUTTON TO INSTALL WASTE ELBOW ONTO BOWL. AFTER WASTE ELBOW IS INSTALLED, REINSTALL VALVE AND ADJUST FLOW.
5. REFER TO 5874SS OPERATION AND MAINTENANCE MANUAL FOR PUSH BUTTON AND VALVE INSTALLATION/MAINTENANCE INSTRUCTIONS.

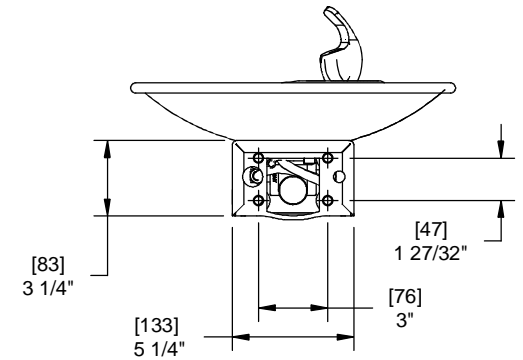
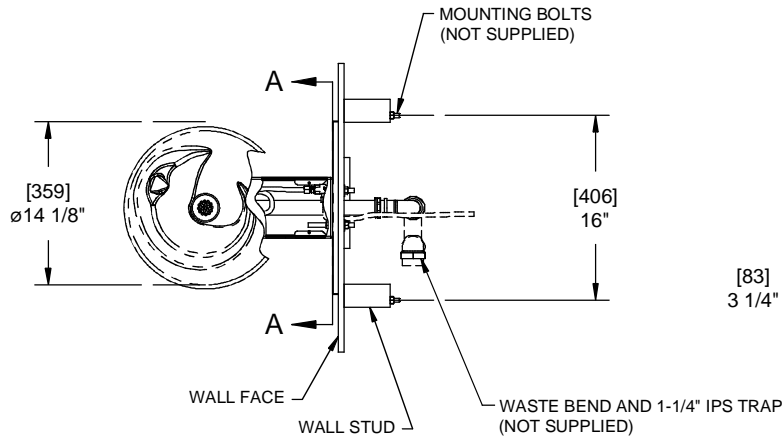

**SECTION A-A
ROTATED 90° INTO VIEW
BRACKET MOUNTING
DETAIL**

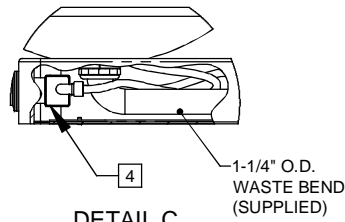

DETAIL C

3

BACK PANEL (OPTIONAL):
1001 & 1001HPS
(STANDARD):
1001BP & 1001HPSBP

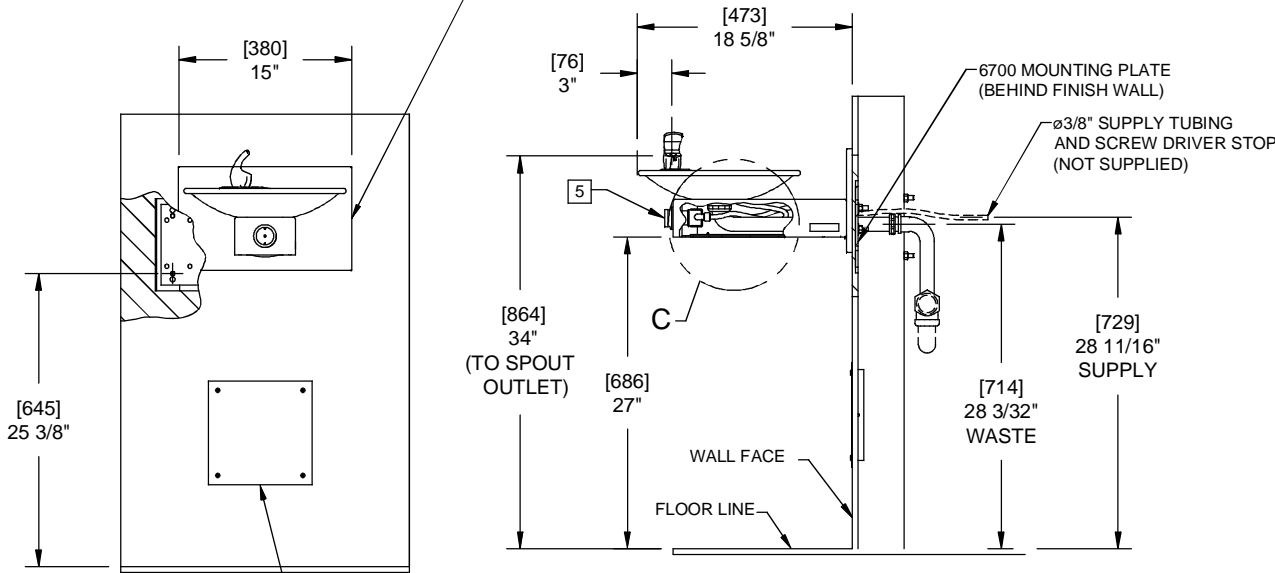

OPTIONAL TRAP ACCESS PANEL
MODELS 6603 AND 6603HPS

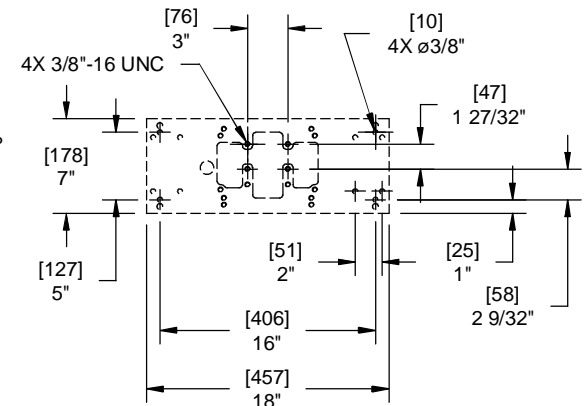

**6700 MOUNTING PLATE
MUST BE INSTALLED BEFORE
FINISH WORK. THIS PLATE IS A
STANDARD ITEM.**



1455 KLEPPE LANE
SPARKS, NEVADA 89431
(775) 359-4712 FAX (775) 359-7424
E-MAIL: HAWS@HAWS.CO.COM
WEBSITE: WWW.HAWS.CO.COM

ECN NO. REVISED PER BY:	MODEL(S)	PART NUMBER:
ECN: 4828 HM	1001/1001BP/1001HPS/1001HPSBP	0002076304.D
DRAWN: RTM	DATE: 05/97	CHKD:
APPROVED:	DATE:	REV. 17
SCALE: 1:1		DRAWING TYPE: INSTALLATION
SIZE: A		SHEET 1 OF 1

REVISED 15990A000